

POWERDUCT SERIES BUSWAY

Installation Manual

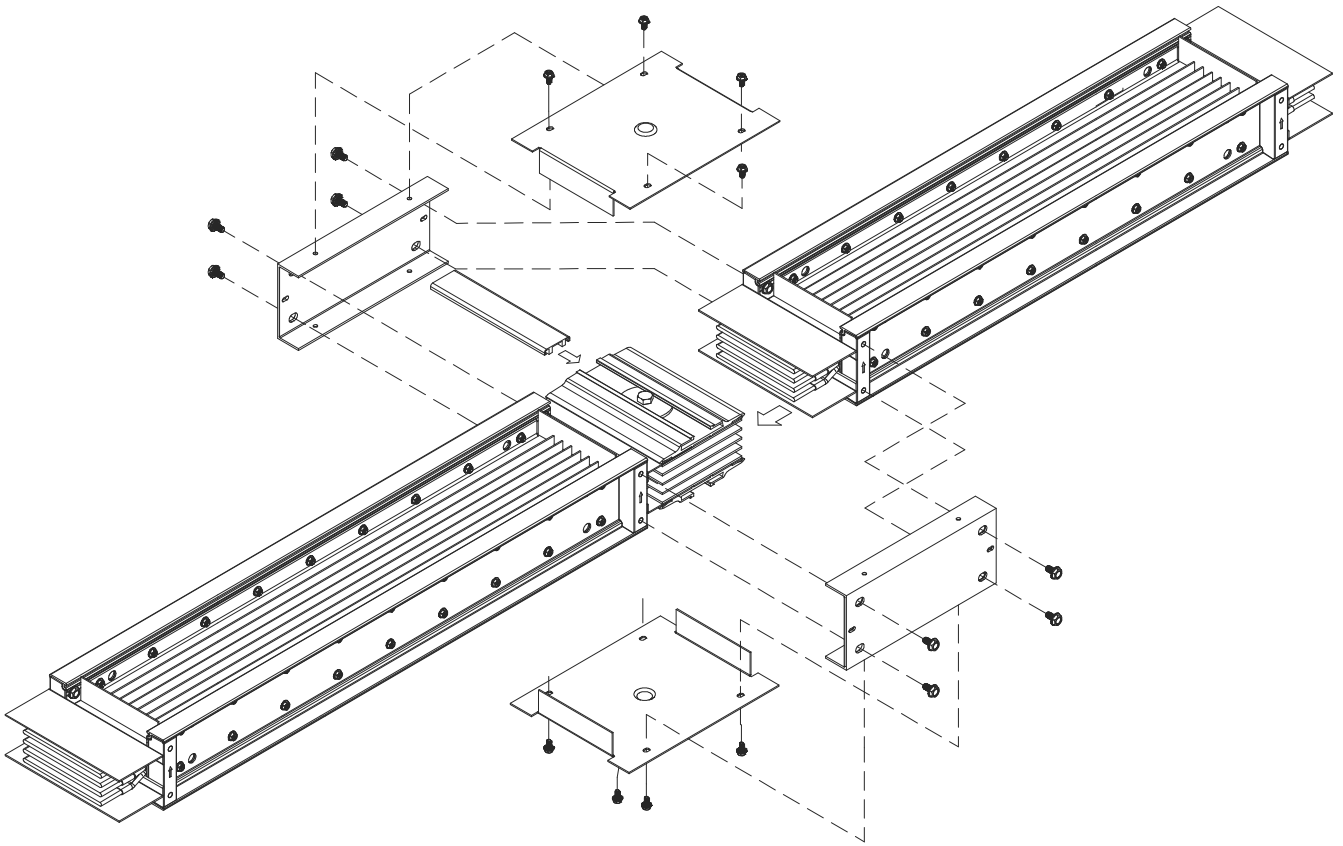

Table of Contents

General Information

Introduction	1
General Information	1
Handling (Including Unpacking)	1-2
Storage Precautions	2
Hold element measuring	3-4
Pre-Installation Procedure	5
Busway Installation	5

Busway Installation for IP54 & IP55

Joining Busway Procedures	6-7
---------------------------------	-----

Busway Installation for IP56, IP65 & IP66

Installation Procedures	8
-------------------------------	---

IP Gel Installation Procedure

Horizontal Position (I)	9
Horizontal Position (II)	10
Vertical Position	11

Busway Mounting

Horizontal Mounting	12
Vertical Mounting	13-14
Expansion Fittings	15

Tap-Off Box Mounting

Installing Tap-Off Unit	16-21
Removing Tap-Off Unit	21
Horizontal Mounting	22

Busway Maintenance Procedures

Maintenance Procedures	23
Inspecting Current-Carrying Components	23
Energizing	23

Busway Installation Checklist	24-26
-------------------------------------	-------

General Information



Introduction

This publication is a guide of practical information containing instructions for handling, installation, operation and maintenance of Powerduct busway and some busway accessories. These recommendations and guidelines will be valuable to electrical engineers, electrical contractors, electricians, maintenance engineers and others person who responsible for the handling, installation, operation and maintenance of Powerduct. This manual will be updated to reflect certain relevant developments in Powerduct.

General Information

Please read the following warning very carefully before proceeding with any installation, operation and maintenance of Powerduct busway.

Warning:

Please take extreme caution when working in or around electrical equipment as there is a hazard of electrical shock can cause severe injury.

1. It is important to have good communications with air-conditioning, plumbing and heating contractors and other site personnel for proper planning and coordination ,which will result in good busway layout.
2. The successful operation of Powerduct will depend to a large degree on proper handling, installation, operation and maintenance as per stated in this manual .Failure to follow fundamental installation and maintenance requirements could lead to personal injury and subsequent damage to the busway (or even loss of the busway) and other property.

Handling (Including Unpacking)

These guidelines are provided to help reduce the risk of personal injury and equipment damage during handling.

1. Always take good care while unpacking.
2. Use nail pullers for unpacking wooden crates to void damage.
3. Take good care when handling busway. Do not subject busway to twisting, denting impact and from of rough handling which can result in damage to internal components and the housing or its finish.
4. Never use bus bar ends for lifting busway sections fittings. Apart from running the risk of dropping the busduct. This method of lifting busway can also cause injury. If a crane (overhead or other) is used for busway installation , use nylon straps to balance the weight of each lift. Open up busway packaging sufficiently to check it for concealed damage as well as to make sure shipment is complete and correct.

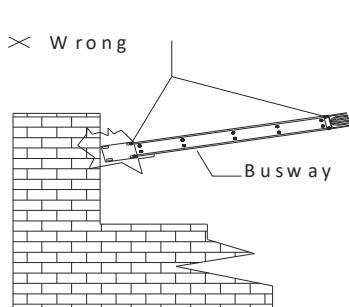

Figure 1.1 Void rough handling

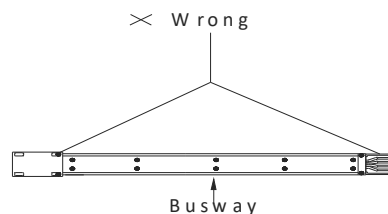

Figure 1.2 Do not use busbar ends for lifting

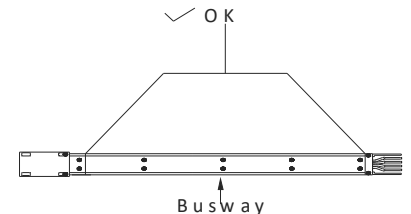

Figure 1.3 Use a balanced set up for lifting busbar section

General Information

5. Open up busway packaging sufficiently to check it for concealed damage as well as to make sure shipment is complete and correct.
6. If the busway are not required for immediate installation and need to be stored for some time restore the packaging for protection.
7. Know the capacity of the moving means (overhead crane, hoists block & tackle etc.) available to handle the weight of the busway sections and fitting. Refer to Powerduct Catalogue to check the weight of straight lengths.
8. Forklift trucks can be used to effectively handle busway. With a forklift, busway can be hoisted between floors with ease. Power operated lifts or elevators can be used to effectively move busway between elevations.
9. Do not drag the busway across the floor this can damage the housing and finish (paintwork).

Storage Precautions

Before storing, unpack thoroughly to make a check of the Busway for possible concealed damage and notify the shipper immediately for any damage reported. If the Busway is free of damage, restore the packing until ready for installation. Store indoors in a clean, dry area, preferably close to the installation points. Protect the Busway from mechanical damage and any contact with or exposure to corrosive fumes, liquids, salts, or concrete. Failure to store and protect the busway properly can cause serious damage and will **void the warranty.**

1. Always store busway in clean and dry place having a uniform temperature to prevent condensation. Ensure that the busway are protected from dirt, fumes, water and physical damage.
2. Do not store busway in a outdoor environment. If busway must be stored outdoor, make sure that the busway are securely covered to provide maximum protection from weather (mainly rain) and dirt (see Figure 2).
3. Out door busway (weather proof) and indoor busway should be treated the same until they are fully installed.
4. For vertical rise, it is good practice to store busway on the floor above where they will be installed, so that they can be easily lowered into position.

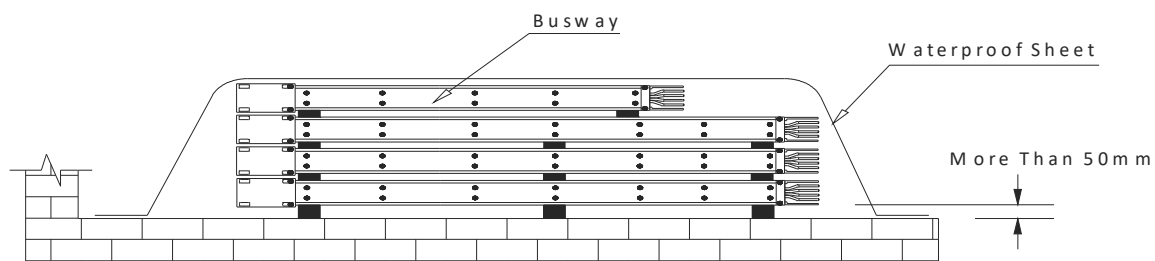

Figure 2. Outdoor storage method

General Information



Hold Element Busway Measuring

Hold element is the busway part which is the dimension is not confirm in the early stage of the design. The customer will later measure the busway length for final fitting.

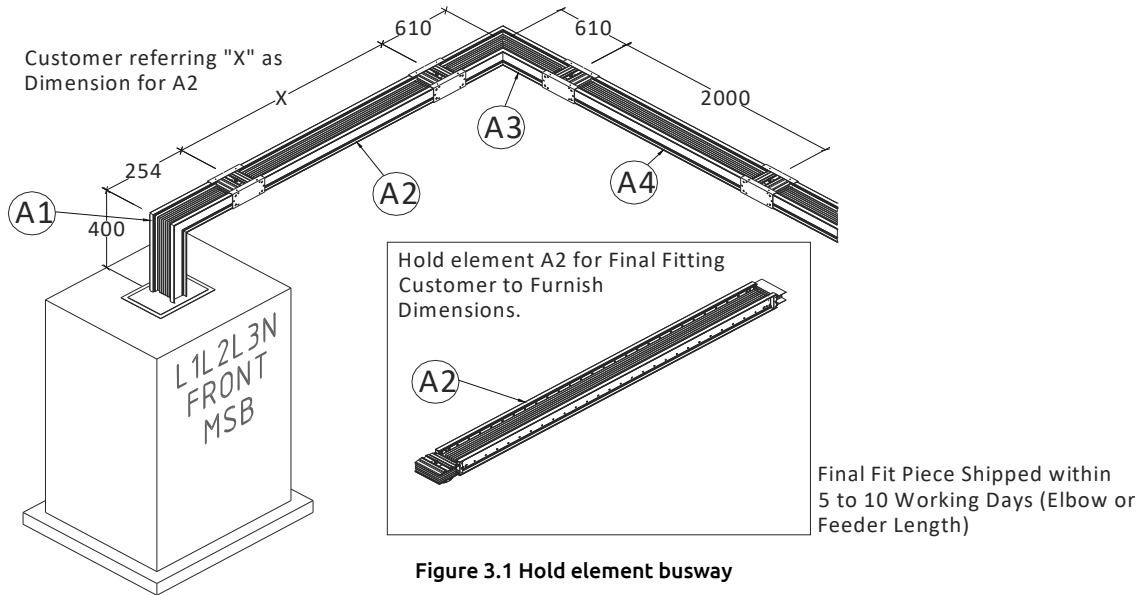
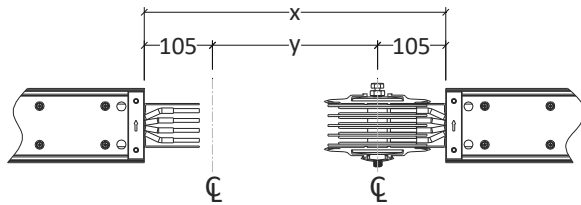

Figure 3.1 Hold element busway

How to measure the busway length

3.1 Straight Feeder Unit (FST)



The nominal dimension "y" of the feeder unit is subtracting 210mm from the dimension "x" measured. Example dim. $x = 1523 - 210 = 1313\text{mm}$ dim "y".

Figure 3.2 – Straight Feeder Unit (FST)

3.2 Edgewise Elbow (EDW)

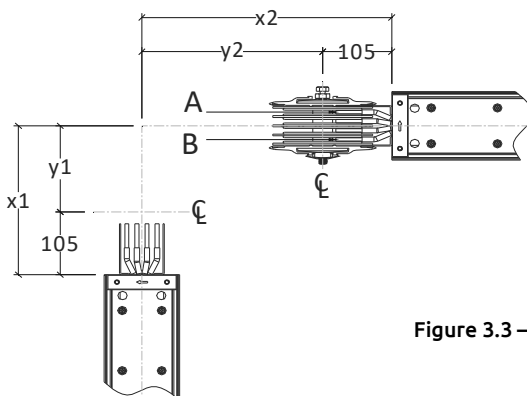

The nominal dimension "y1" and "y2" of the elbow unit is obtained by subtracting 210mm from the dimension "x1" and "x2" measured.

Neutral position should be indicated (A or B)

Figure 3.3 – Edgewise Elbow (EDW)

3.3 Flatwise Elbow (FLW)

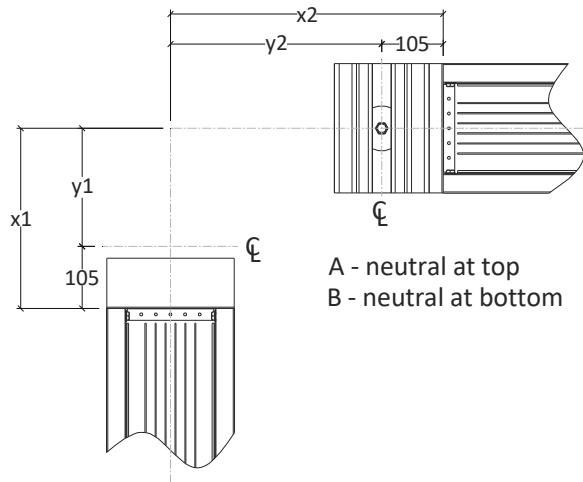

The nominal dimension "y1" and "y2" of the elbow unit is obtained by subtracting 210mm from the dimension "x1" and "x2" measured.

Neutral position should be indicated (A or B)

Figure 4.1 – Flatwise Elbow (FLW)

3.4 Flatwise Offset (FO)

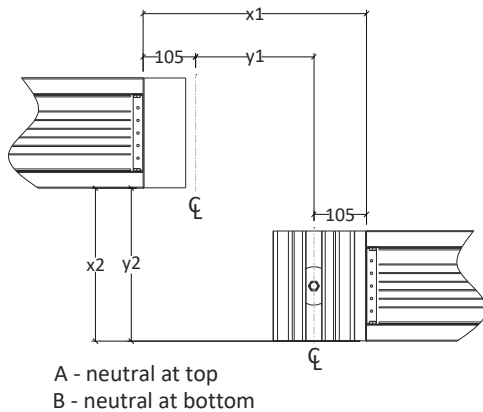

The nominal dimension "y1" of the elbow unit to be ordered is obtained by subtracting 210mm from the dimension "x1" measured. The "x2" is the nominal dimension.

Neutral position should be indicated (A or B)

Figure 4.2 – Flatwise Offset (FO)

3.5 Edgewise Offset (EO)

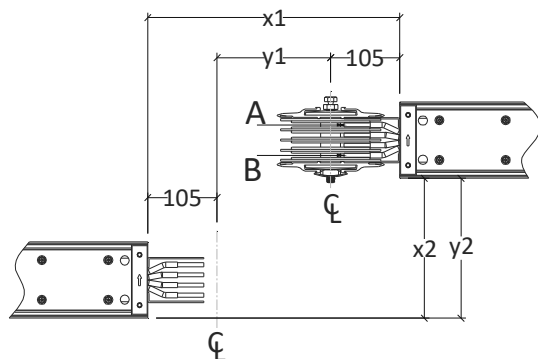

The nominal dimension "y1" of the elbow unit to be ordered is obtained by subtracting 210mm from the dimension "x1" measured. The "x2" is the nominal dimension.

Neutral position should be indicated (A or B)

Figure 4.3 – Edgewise Offset (EO)

General Information



Pre-Installation Procedure

If possible, please deliver the busway to its installation location before unpacking. Large labels on each shipping carton or crate designate the items contained. Additionally, each Busway piece is identified with an serial number label. Inspect each Busway piece for possible damage or contamination. Contact surfaces must be clean. However, do not attempt to polish tarnished contact surfaces. Check to ensure that joint insulators are not damaged or cracked and are firmly in place. ***Mega ohm test each piece before installation.***

Busway Installation

Establish the bus bar phase sequence (Arrow on the end block) to determine how the Busway is to be installed, so that correct phasing is maintained throughout the system. Note that phase transposition lengths, when furnished, may relocate the Arrow to the opposite direction of a Busway run. Each Busway section has a “bar end” and a “joint end”, as illustrated in Figure 5. Normally the busway is oriented end with bar ends pointing away from the source. In vertical risers installations, it is easier to lower the busway into place than it is to raise it.

If installation drawings have been furnished, information regarding the orientation of the Busway end for end, and direction of the Arrow, as well as other pertinent data, will be furnished. These drawings should be followed carefully to ensure a proper Busway system.

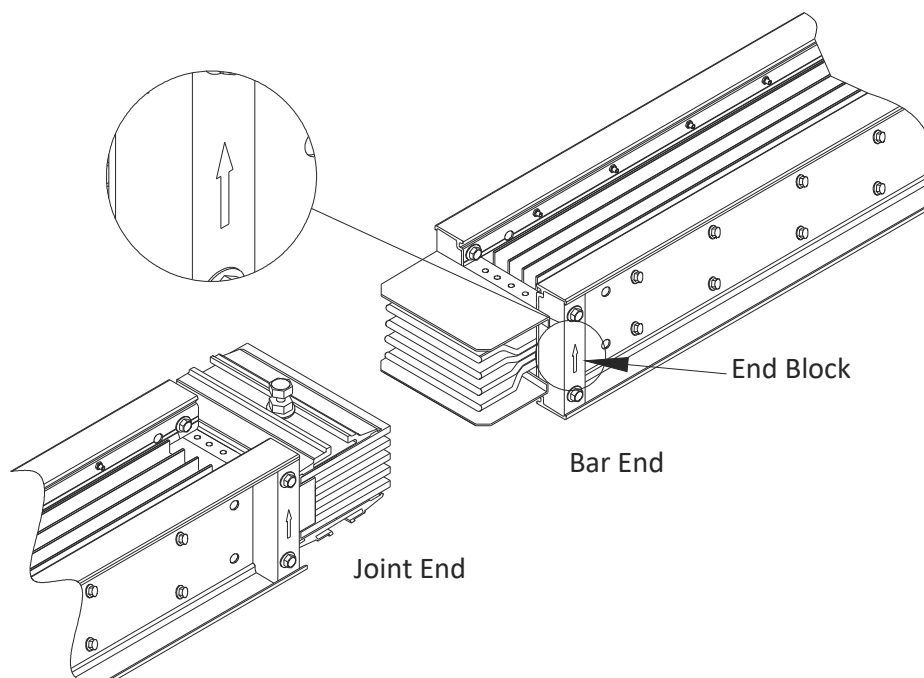

Figure 5. The bar end and joint end of the busway

Busway Installation for IP54 & IP55

Jointing Busway Procedure

1. Remove both joint cover, shown in Figure 6.1 , 2. Aligned the busway to be joined by matching up arrow. If necessary, loosen the joint bolt.

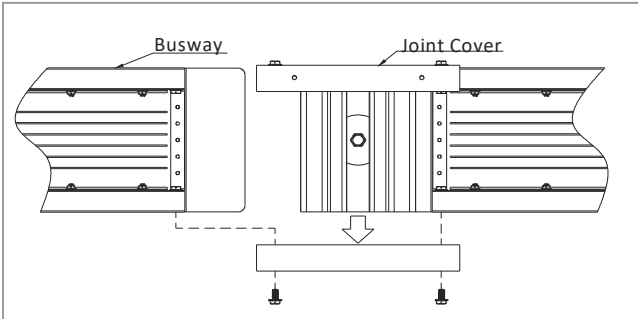

Figure 6.1. Top view

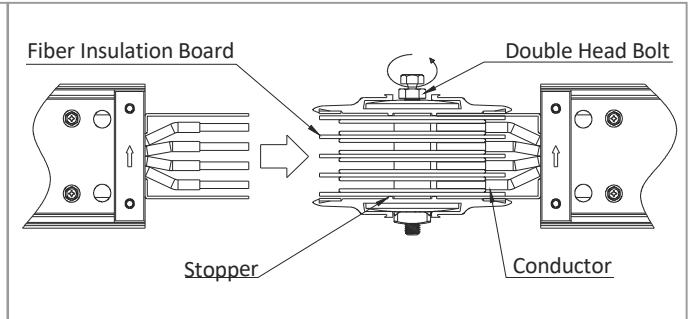

Figure 6.2. Front View

3. Pull the steel rod as per arrow direction using installation tool kit shown in Figure 6.3

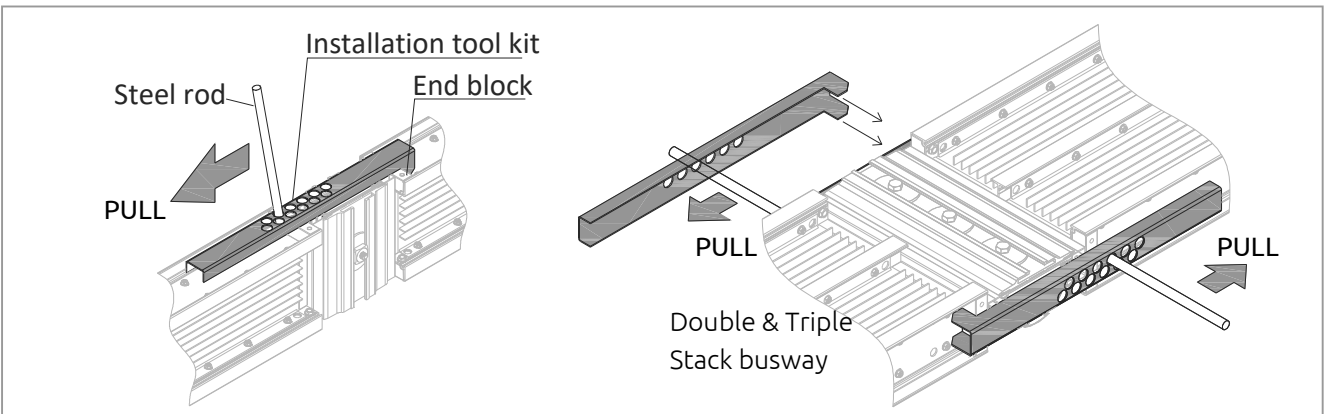

Figure 6.3

CHECK!!

- ◆ Slop in the busway until the phase of the busbars to stopper. *It shall not be over-lapped the stopper as per* Figure 6.4.
- ◆ Each busbars phase shall be separated by the fiber insulation board Figure 6.4

Figure 6.4

- ◆ Contact between the fish plate and the phase conductor shall be parallel to provide excellent contact shown in Figure 6.5.

Figure 6.5

Busway Installation for IP54 & IP55



4. Tighten the screw until the screw cap is broken and the tag fall (Figure 7.1 & 7.2) means the torque is applied. If necessary, use the torque wrench for double checking the tighten of the bolt. ***Make sure the minimum torque is 50 lb-ft or 68N-m.***

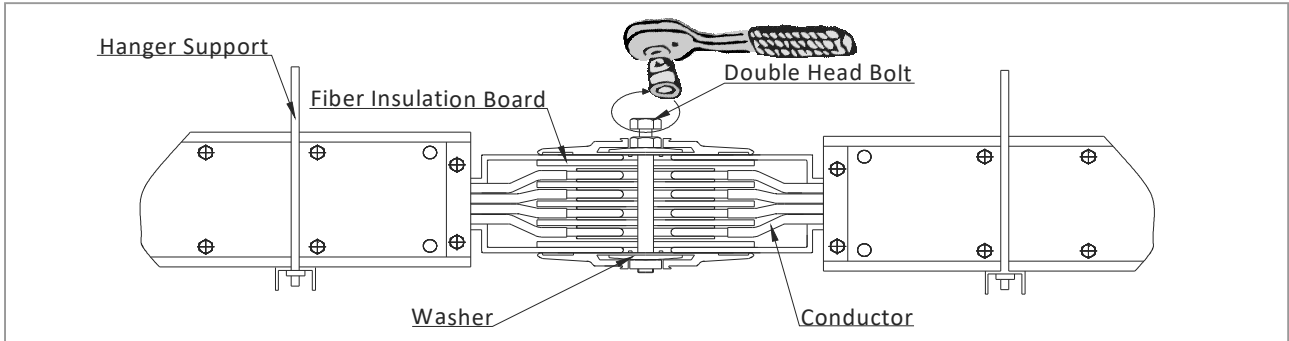

Figure 7.1

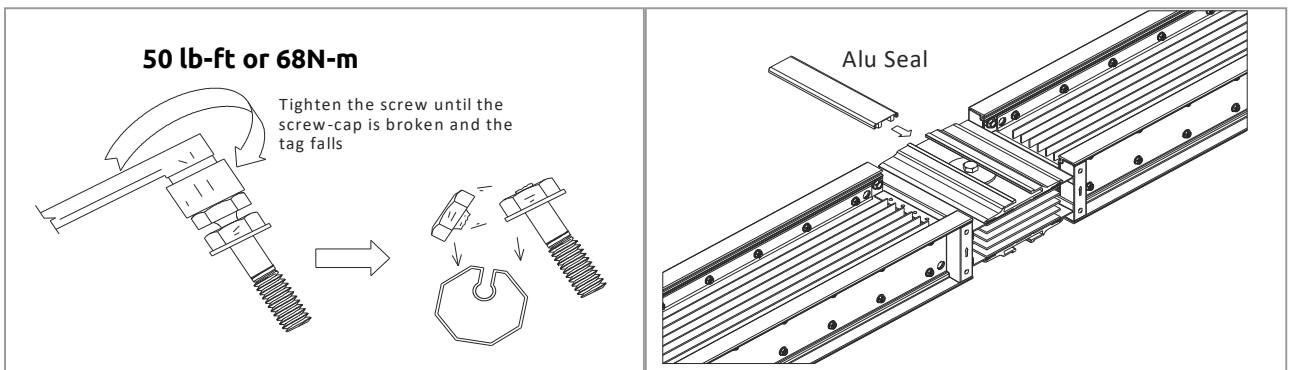

Figure 7.2

Figure 7.3

4. Install the alu seal as shown in Figure 7.3.

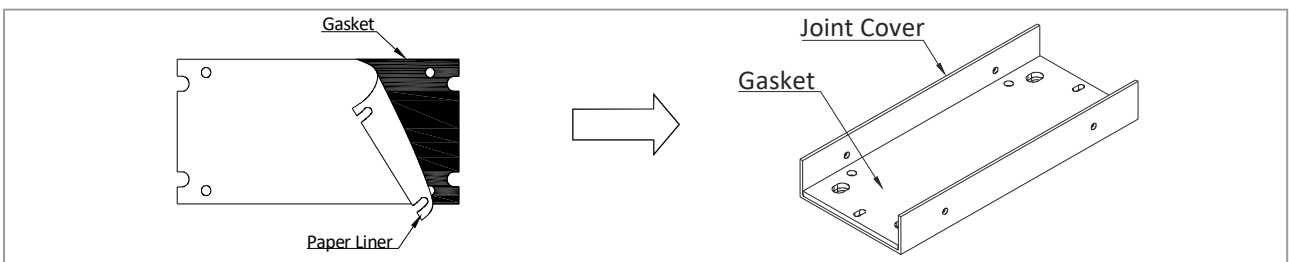

Figure 7.4

5. Paste the gasket to joint cover as shown in Figure 7.4.
6. Install back the joint cover as shown in Figure 5.5. Complete installations.

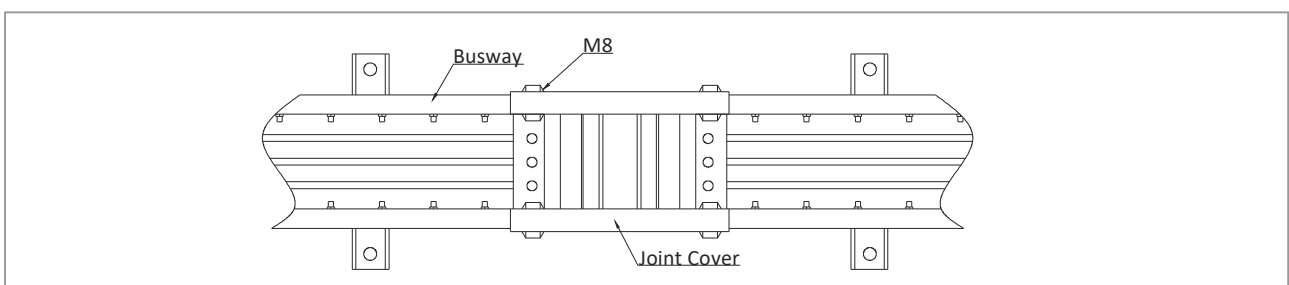

Figure 7.5

Busway Installation for IP56, IP65 & IP66

Installation Procedures

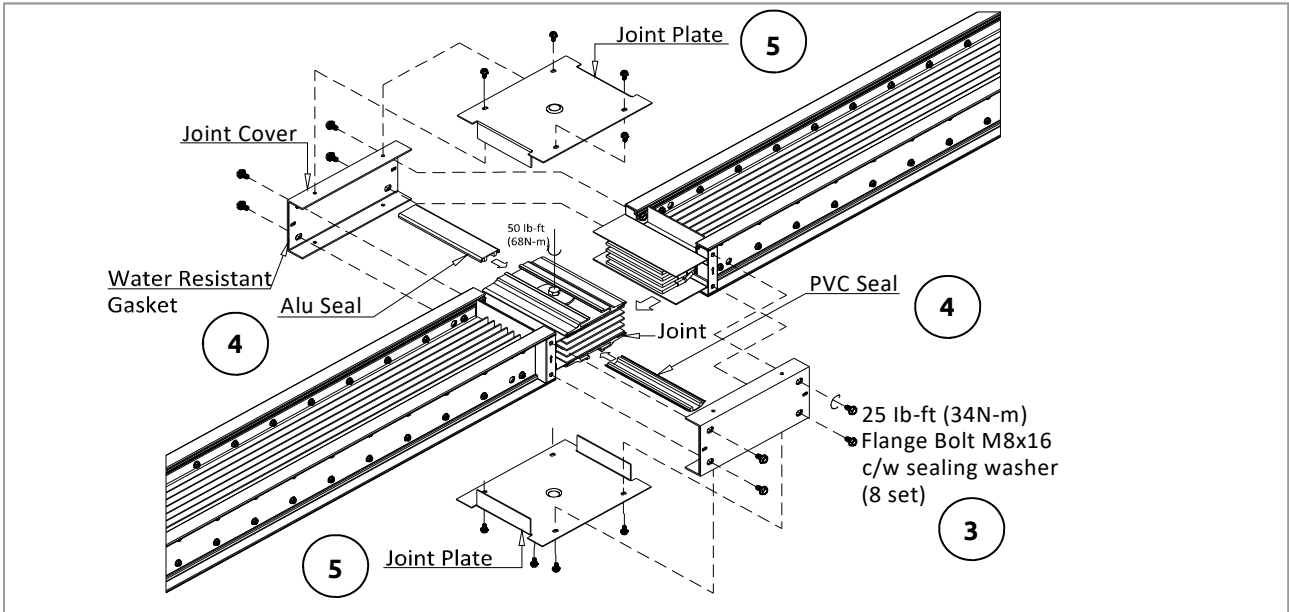

Figure 8.1 Assembly of outdoor busway joint. Correct way to assembly of joint shields is illustrated.

Steps in installing outdoor busway system:

1. Gasket will be provided as shown in Figure 8.2
2. Paste it on inner part of joint covers.
3. Joint two feeder together, and eventually attach joint cover on both sides of the joint with flange bolt and sealing washer as shown in Figure 8.1
4. Attach Alu seal and PVC seal on the top of joint as shown in Figure 8.1
5. Assemble the joint plate as shown in Figure 8.3
6. Apply sealant to enhance gasket areas as shown in figure 8.3 at both side of the joint plates.

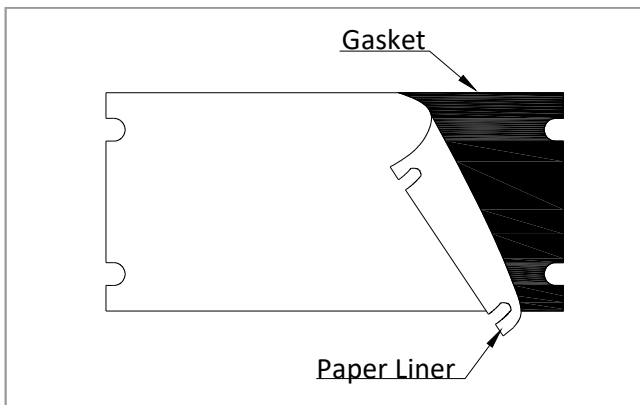

Figure 8.2. Water resistant gasket

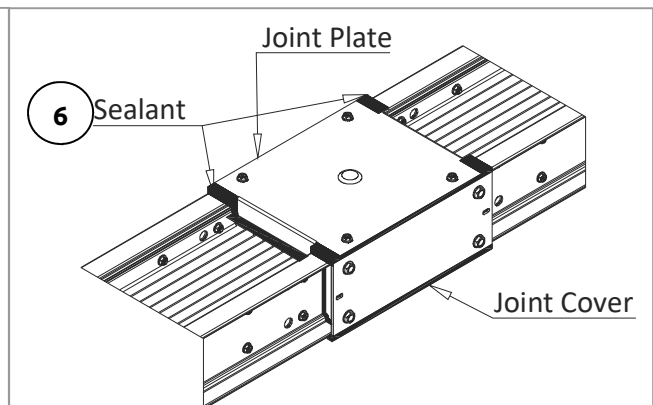

Figure 8.3 Water resistant / Outdoor joint

IP Gel Installation Procedure



IP Gel Preparation

1. Shake well both compound A & B before pour into container.
2. Pour compound A & B into container.
3. Mixed the compound together. Compound A and B ratio is 1:1. Mixing one time per set and avoid mixing in a big batch to prevent hardening before pouring into busway.



Horizontal Position (I)

1. Joint two feeder together, and install alu seal and pvc seal as shown in Figure 9.1
2. Remove all hole plug from end block and alu 'S', apply sealant around all the hole (See Figure 9.2)
3. Plug the hole plug as per Figure 9.2 into inner side of busway joint.
4. Install the joint cover at the bottom of the busway as shown in Figure 9.3
5. Prepare the IP Gel.
4. Pour the mixed compound onto the area until full as shown in Figure 9.4. Complete cure time is in 8-12 hours @ 25°C or 1 hour @ 80°C.
5. Installed back the top joint cover as shown in Figure 9.5
6. Complete Installation.

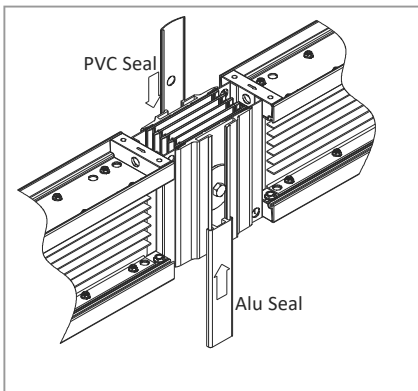

Figure 9.1

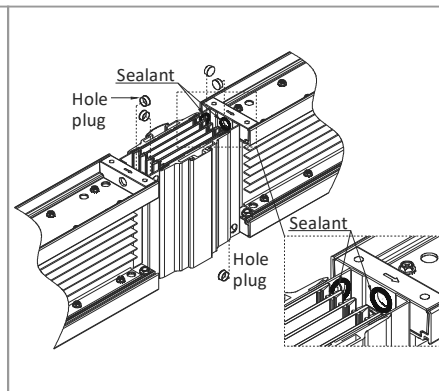

Figure 9.2

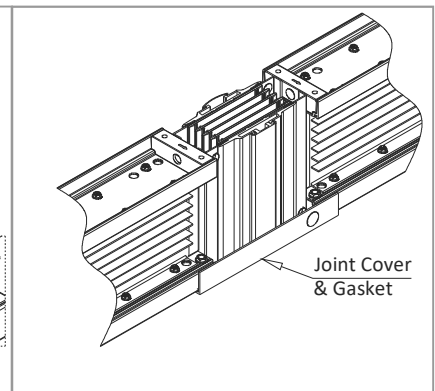

Figure 9.3

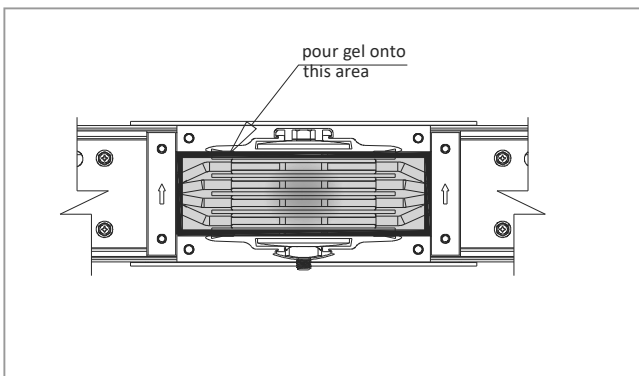

Figure 9.4

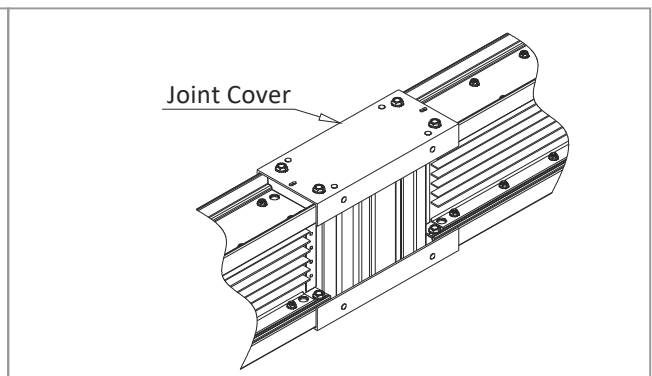

Figure 9.5



Horizontal Position (II)

1. Joint two feeder together, and installed alu seal and pvc seal as shown in Figure 10.1
2. Remove all hole plug from end block and alu 'S', apply sealant around (inner side of busway joint) all the hole except top side of alu 'S' (See Figure 10.2)
3. Plug the hole plug for all end block and bottom alu 'S' as per Figure 10.2 into inner side of busway joint.
4. Installed the joint cover for both side of the busway and remove the hole plug (2pcs) as shown in Figure 10.3
5. Prepare the IP Gel.
6. Concurrently pour the mixed compound into both holes using liquid funnel until full as shown in Figure 10.4. Complete cure time is in 8-12 hours @ 25°C or 1 hour @ 80°C.
7. Placed back all the top side hole plug which removed earlier as shown in Figure 10.5
8. Complete Installation.

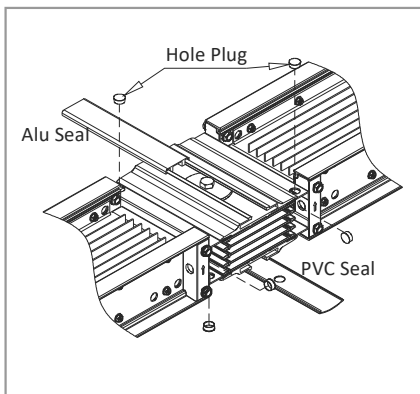

Figure 10.1

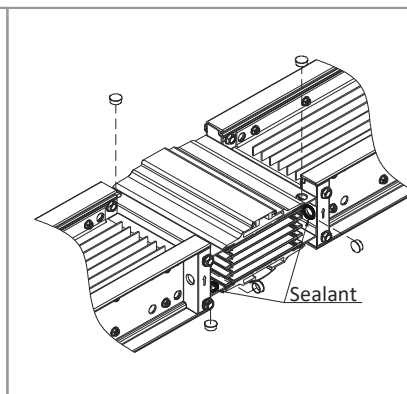

Figure 10.2

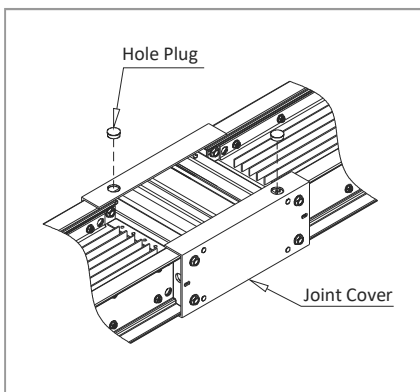
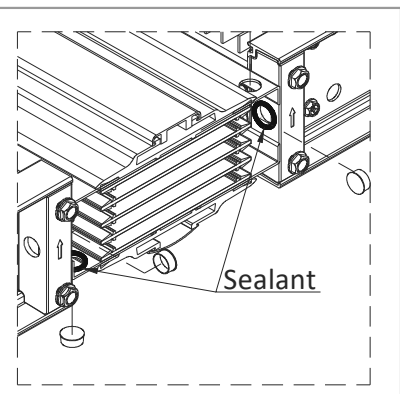

Figure 10.3

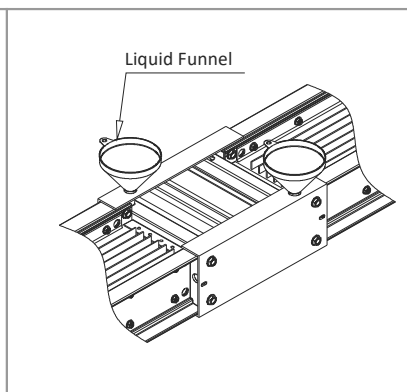

Figure 10.4

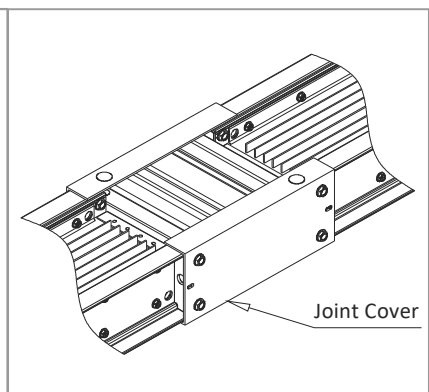

Figure 10.5

IP Gel Installation Procedure



Vertical Position

1. Joint two feeder together, and install alu seal and pvc seal as shown in Figure 11.1
2. Remove all hole plug from end block and alu 'S', apply sealant around all the hole (See Figure 11.2)
3. Plug the hole plug as per Figure 11.2 into inner side of busway joint except the top side of end block.
4. Install the both joint cover. (Figure 11.3)
5. Prepare the IP Gel.
6. Place the liquid funnel into the hole as shown in Figure 11.4
7. Pour the mixed compound onto the area until full as shown in Figure 11.4. Complete cure time is in 8-12 hours @ 25°C or 1 hour @ 80°C.
8. Complete installations.

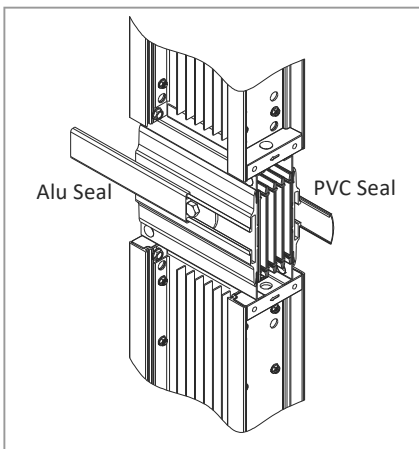

Figure 11.1

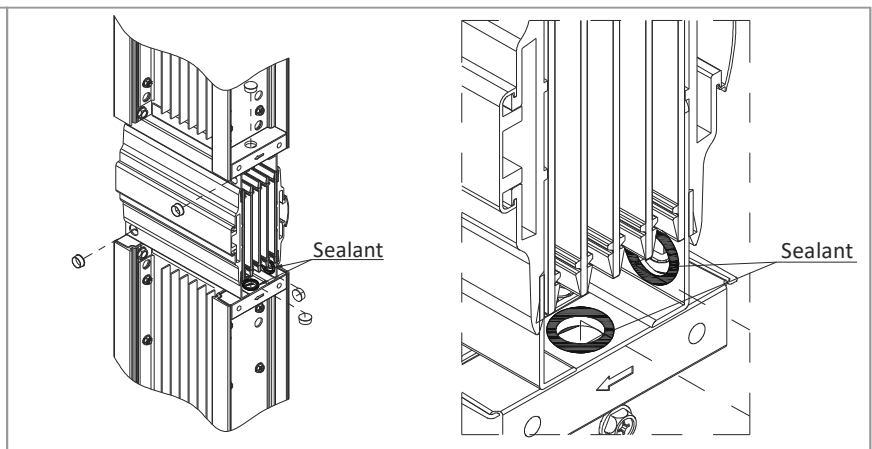

Figure 11.2

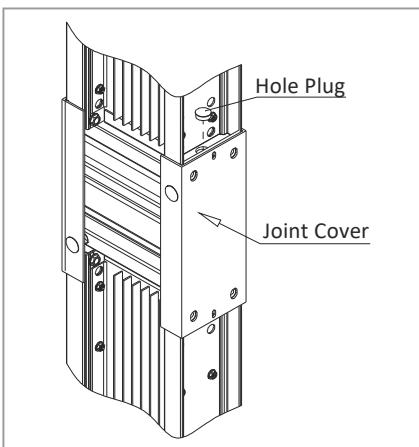

Figure 11.3

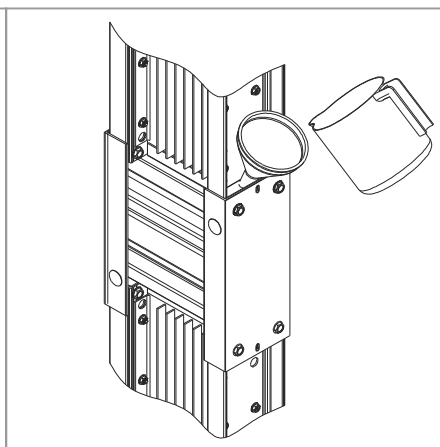

Figure 11.4

Horizontal Mounting

Overhead Support

For overhead-supported busway, 1/2 inch drop rods are recommended with a maximum 2.5meter spacing. Drop rods and other hardware must be furnished by the installer. Figure 12.1 illustrates mounting dimensions for typical installations:

- ◆ Maintain good alignment of the drop rods along the busway run.
- ◆ Do not support busway at the joints.
- ◆ After the busway is secured in the hangers, adjust the hangers on the rods for the correct elevation.
- ◆ Sway braces (furnished by the installer) may be required to keep the run straight or to prevent rotation.
- ◆ Manufacturer recommended each 1 meter busway adjacent must have busway cleat supported. Please check with manufacturer if cleat quantity provided is insufficient.

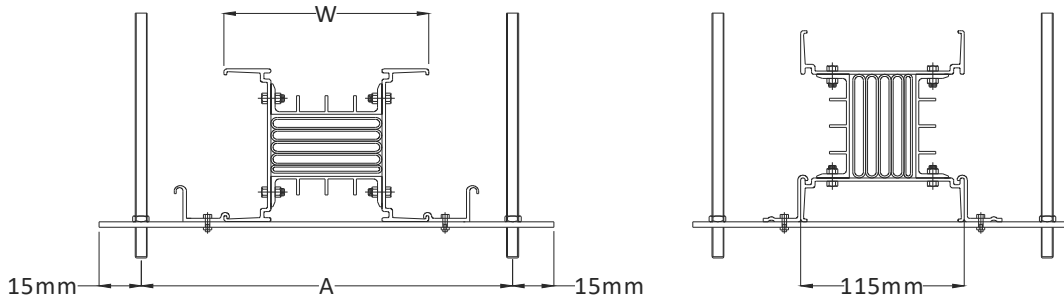
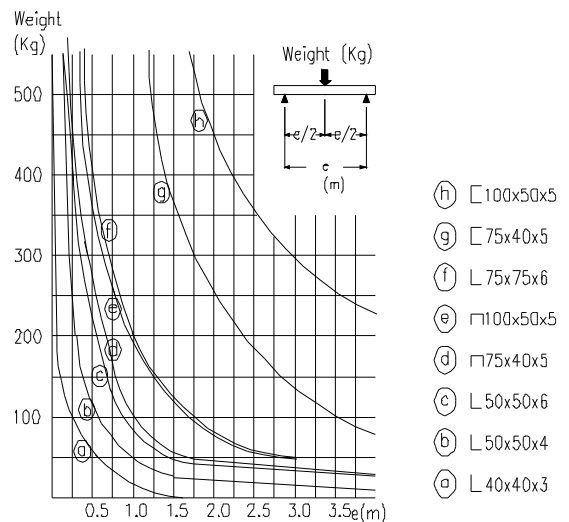

Figure 12.1 Dimension between drop rods for dual-hanger installations.

Bars per Phase	Copper		Dim (mm)	Bars per Phase	Aluminum		Dim (mm)
	Ampere Rating	Busway W	Hanger A		Ampere Rating	Busway W	Hanger A
1	400	89	260	1	400	114	260
	600	99					
	800	114					
	1000	129					
	1200	144					
	1350	159					
	1600	179					
	2000	219					
2	2500	269	356	2	1600	234	356
	2000	219					
	2500	375			470		
	3000	405					
	4000	475					
2	3000	295	470	2	3000	405	572
	4000	375					
	5000	475					

Table 12.2 Busway and hanger mounting dimensions, as illustrated in Figure 12.1



Material use for busway support channel.

Suggest to use 12mm or 1/2 inch of steel rod. It is suggest to use 40mm x 3mm support channel for 2000A or below busway model while 50mm x 6mm for 2500A or above busway. Please refer to below data during busway installation.

Busway Mounting



Vertical Mounting

Support busway on maximum 4.8 meter centers. Use Table 14.2 to determine the number of springs required based on busway weight. After placing the length of busway through the floor, follow this procedure to assemble hangers to the busway, as illustrated in Figure 13.1. For convenience in assembly, step 8 may be completed before the hangers are attached to the busway.

1. Loosen the **hanger bolt** , shown in Figure 13.1.
2. Assembly the hangers to each side of the busway.
3. Position the hangers on the busway so that the base channel rests on the floor or other support. A floor flange may be placed under the hanger, but it will not support the busway weight.
4. Fit the hanger clamps to the busway housing and hand tighten the hanger bolts .
5. Anchor the base channels to their supports.
6. Tighten the hanger bolts.
7. Install the next length and make the joint assembly.
8. If springs are furnished, they must be adjusted as shown in Figure 13.1. Determine the required dimension H of the hanger springs, found on the layout drawing or by using the formula;

$$H = 114.5mm - \frac{W}{2.46}$$

$$W = \frac{\text{Busway weight (kg/meter)} \times \text{Height (meter /floor)} + \text{Devices on the floor (kg)}}{\text{Total no of spring}}$$

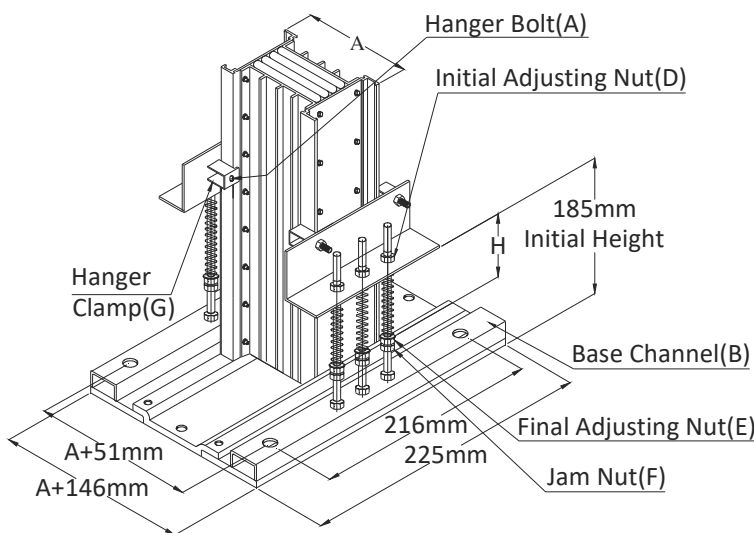

Figure 13.1 Rigid and spring hanger installation

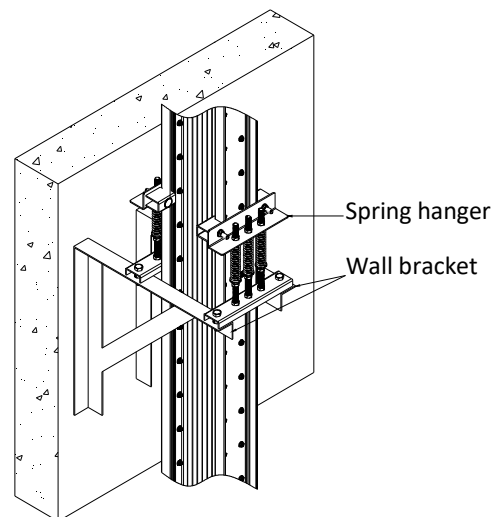

Figure 13.2 Wall bracket and spring hanger installation

Busway Mounting



Using the final adjustment nuts, set the springs on the hangers to the dimension. With the springs adjusted, hold nut in position and tighten jam nut against nut to retain the spring setting. Tighten all jam nuts using this procedure.

Note that when you are calculating the dimension for the bottom floor of a riser with an elbow and busway directly below the floor, the following must be included in the meter calculation:

- ◆ Busway below the floor to the elbow
- ◆ The elbow
- ◆ 2.5 meter of horizontal busway

For the riser to function as a free end, the last horizontal hanger must be 2.4 meter from the bottom elbow.

After the busway run is installed, starting at the top hanger raise the initial adjusting nuts of all hangers to the top of the spring studs. The studs are crimped to hold the nuts in the uppermost position.

Amperes	Busway Weight, Kg/3m			
	Copper		Aluminum	
	3 Wire	4 Wire	3 Wire	4 Wire
400	24	28	21	23
600	29	34	25	28
800	37	45	27	31
1000	41	50	30	35
1200	47	67	35	41
1350	55	78	44	52
1600	64	93	47	55
2000	97	123	58	68
2500	128	162	-	-
3000	141	178	87	104
4000	187	238	108	129
5000	249	317	-	-

Table 14.1 Busway Weights.

Busway Weight, Kg	No. of Springs Required per floor
0 — 250	6
251 — 350	6

Table 14.2 Number of busway springs required per busway weight.

Busway Mounting



Expansion Fittings

Expansion lengths compensate for thermal expansion of a long busway run or for differential expansion between two buildings spanned by a busway run. One end wall of the expansion box is free to move, but only after the **shipping screws** are removed. Install the expansion length and the remaining busway run, as shown in Figure 15. All but the farthest busway supports beyond the box's free end must be non-rigid, such as spring hangers for riser (vertical) busway or drop rod assemblies on a horizontal run. Before energizing the run, remove the **shipping screws**, two on each side of the box.

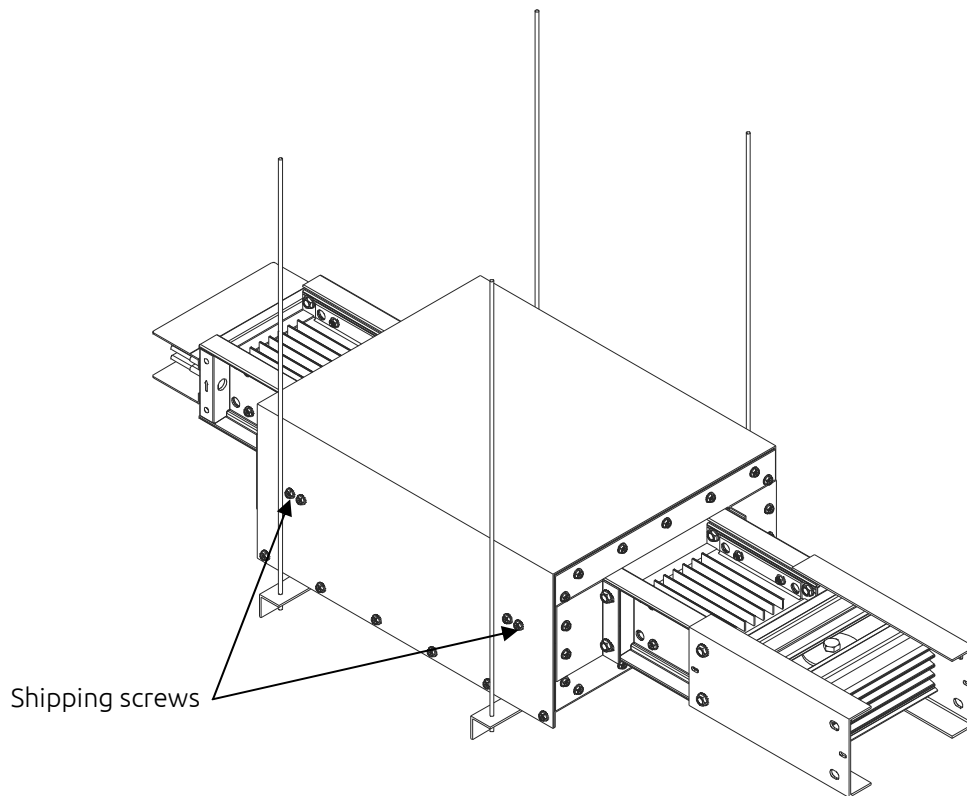

Figure 15. Expansion Joint



Shipping screws must be removed after installation complete.

Tap-Off Box Mounting

Notice the following points concerning busway plugs:

- ◆ Inspect the plug in unit before installing on the busway.
 - A) The plug in unit ampere rating is correct
 - B) The ON/OFF is functioning
- ◆ Stab fingers have been **lubricated with conductive grease**, which should not be removed.
- ◆ An alignment pin polarizes and locates the plug in the correct position only.
- ◆ Plugs are interlocked, permitting engagement and disengagement with the busway only when in the **OFF** position.

Installing tap-off unit

Use the following procedure, as illustrated in Figure 16.1, 16.2 and 16.3

1. Make sure the plug-in unit (PIU) switch in “OFF” position.

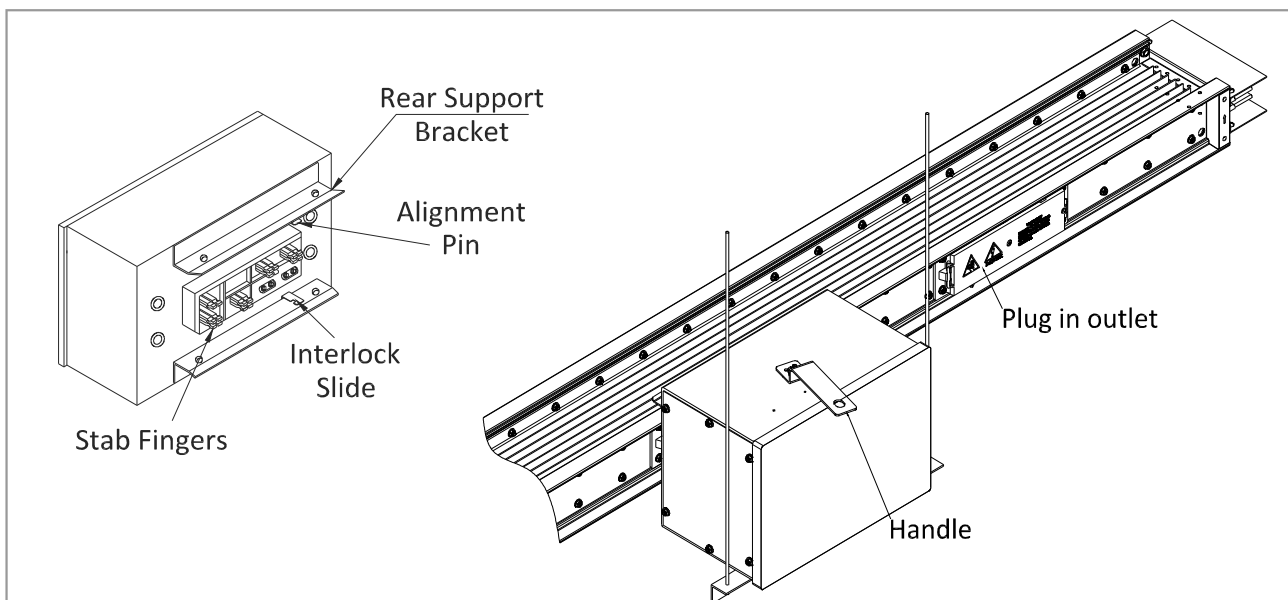

Figure 16.1

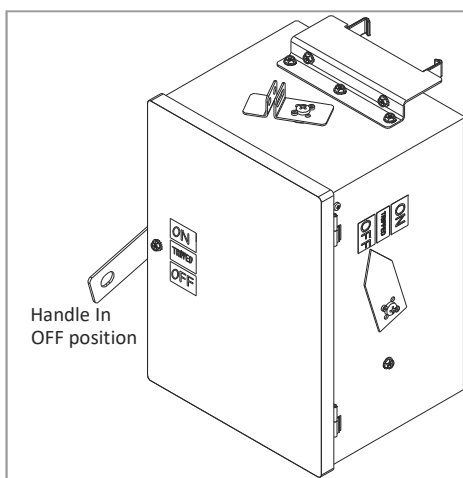

Figure 16.2: Stick hook type

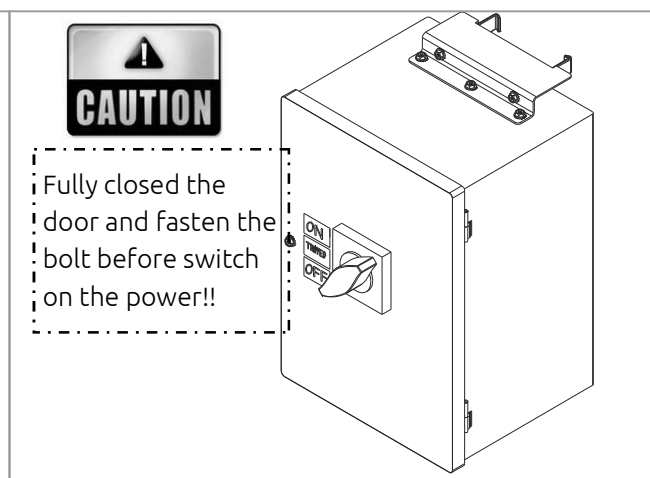

Figure 16.3: Rotary handle type

Tap-Off Box Mounting



Installing tap-off unit

2. Loosen the screw on the top side of the Plug In Unit in Figure 17.1

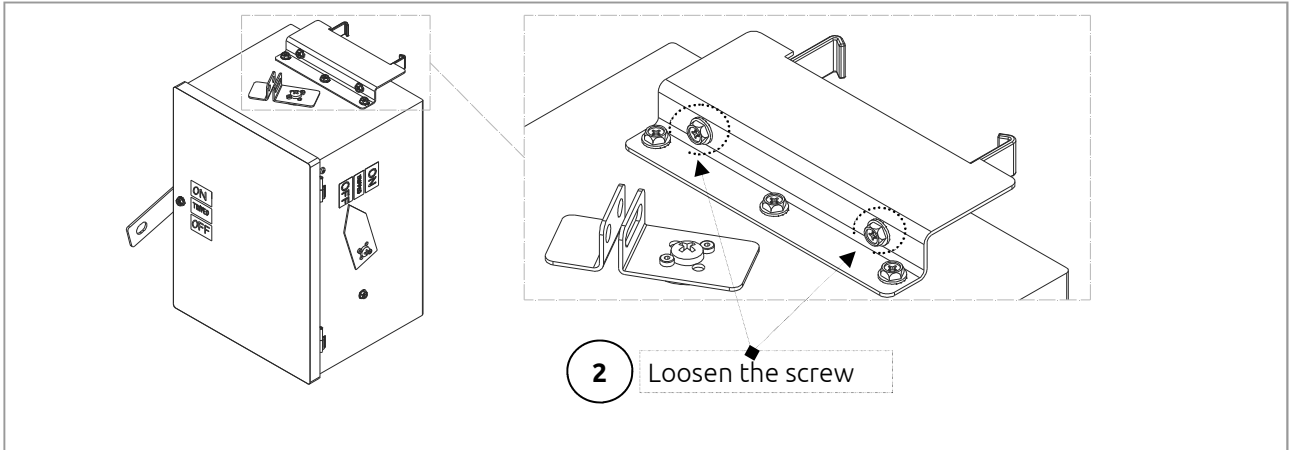

Figure 17.1

3. Remove the self drilling screw (SD) SCREW M6 X19(4 pcs) and M6X 16 screw(4pcs) both side (Figure 17.2)

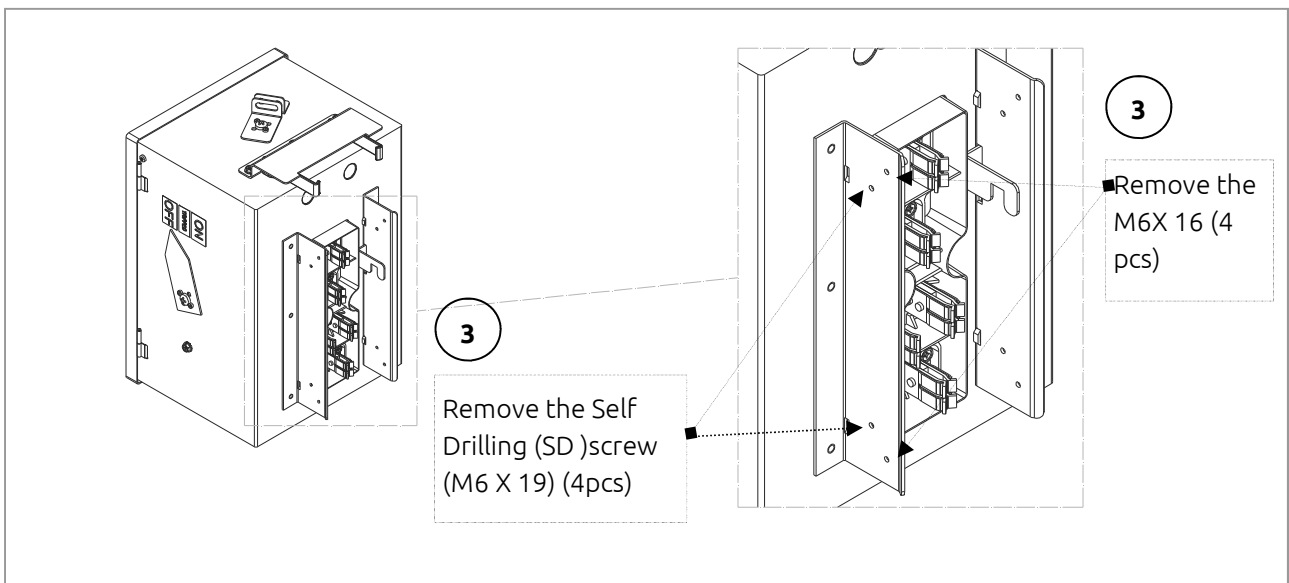

Figure 17.2

Tap-Off Box Mounting

Installing tap-off unit

4. Open the plug in outlet and remove the cover by removing the Phillip screw. (See Figure 18.1)
5. The alignment pin will be inserted into the alignment slot for the installing process. (See Figure 18.2)

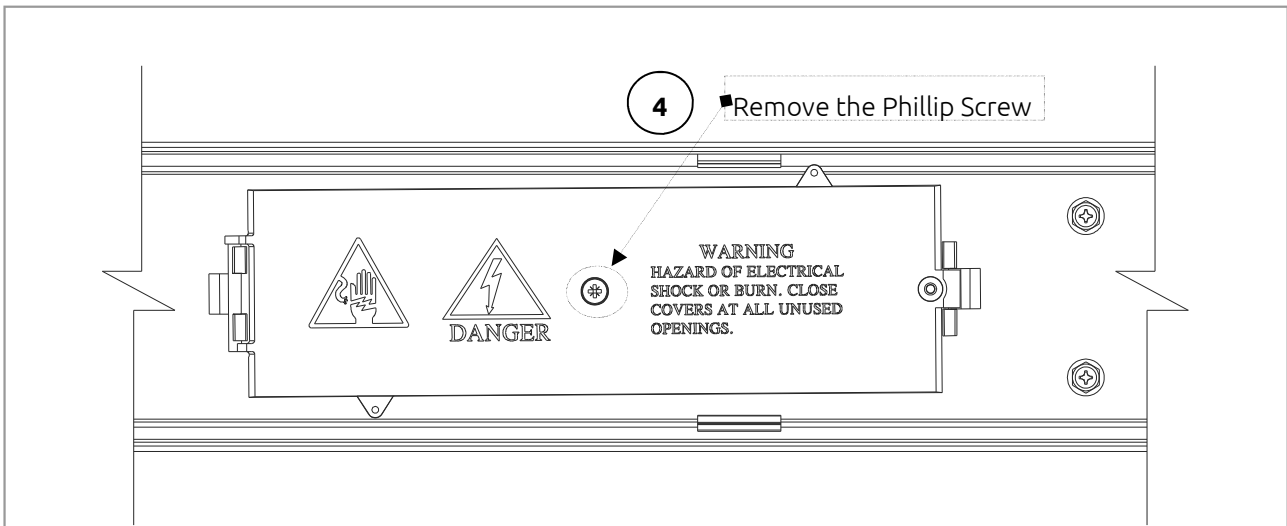

Figure 18.1

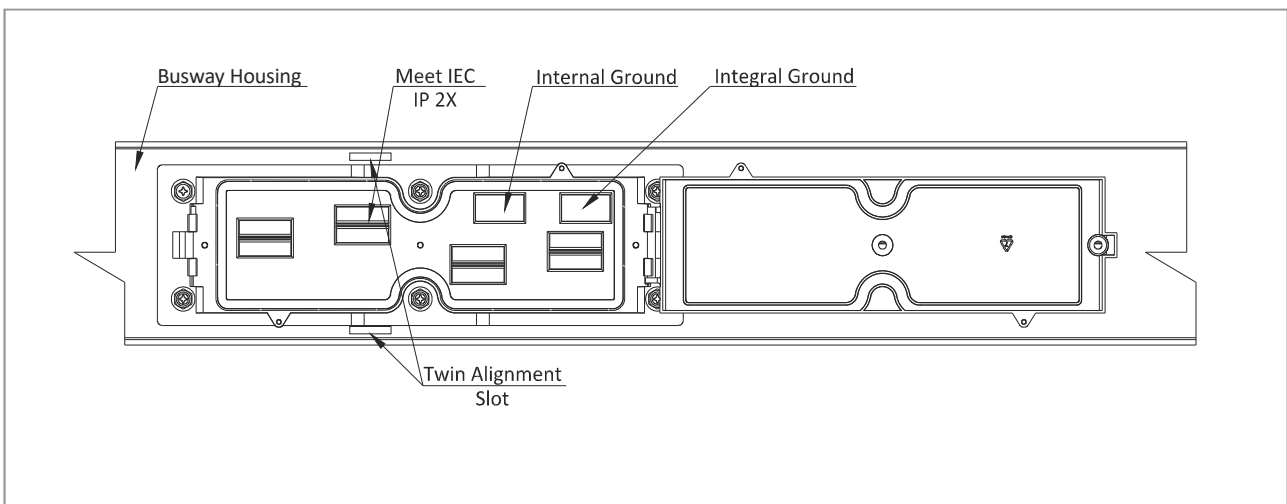

Figure 18.2

Tap-Off Box Mounting



Installing tap-off unit

- Before installing the plug in unit box, install the fix hanger at the bottom of the plug in outlet according to the distance (X) for supporting the plug in unit (Figure 19.1 and 19.2)

* Please refer (Table 19.1) for the ampere rating for the (X) distance accordingly

Ampere rating (A)	Box size (H) mm	Dimension (X) mm
>100	380	170
	500	285
>250	480	270
	620	405
	800	585
>400	580	370
	630	415
	800	585
>800	1060	850

Figure 19.1

Table 19.1

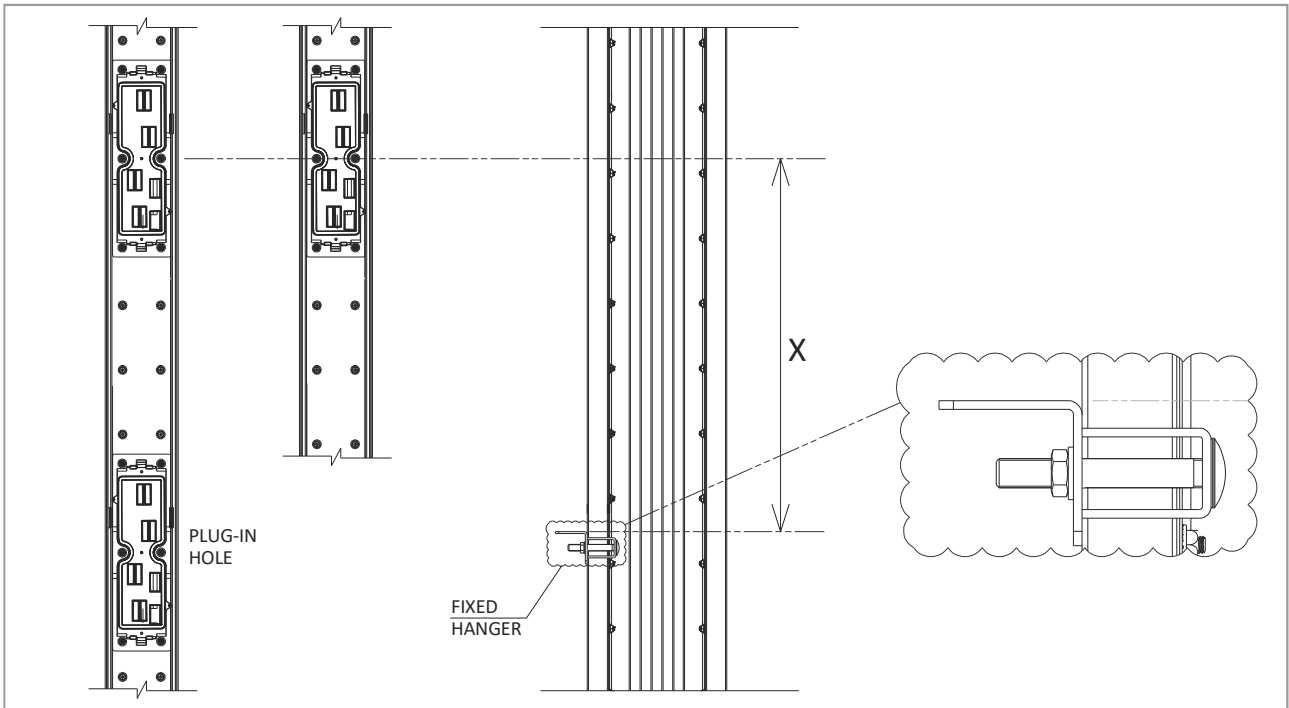

Figure 19.2

Tap-Off Box Mounting

Installing tap-off unit

7. Lift and place the plug in unit on the fix hanger (Figure 20.1)
8. Push the stabs into full contact with the busway and push the upper part until reach the stopper (Figure 20.2 and 20.3)
9. Ensure the alignment pin is inserted into the alignment slot.

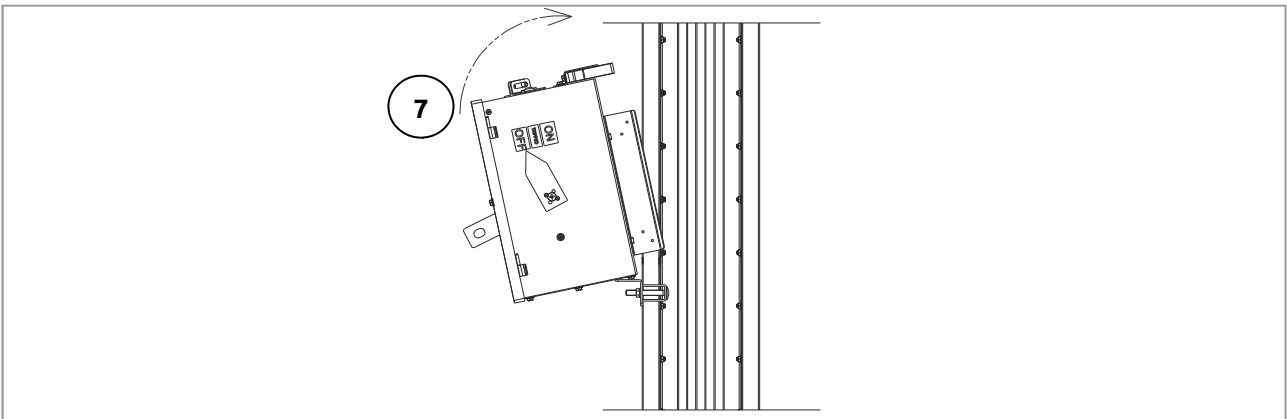

Figure 20.1

10. Tighten the M6 x 16 screw on the upper part for both side
11. Ensure the M6 hole screw is to exceed the side cover before tightening it

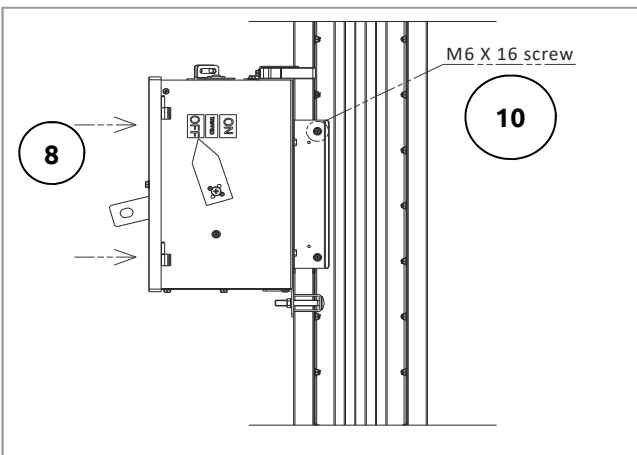

Figure 20.2

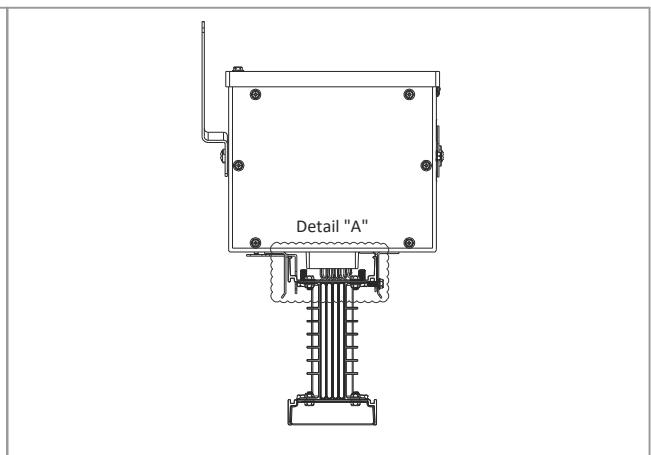
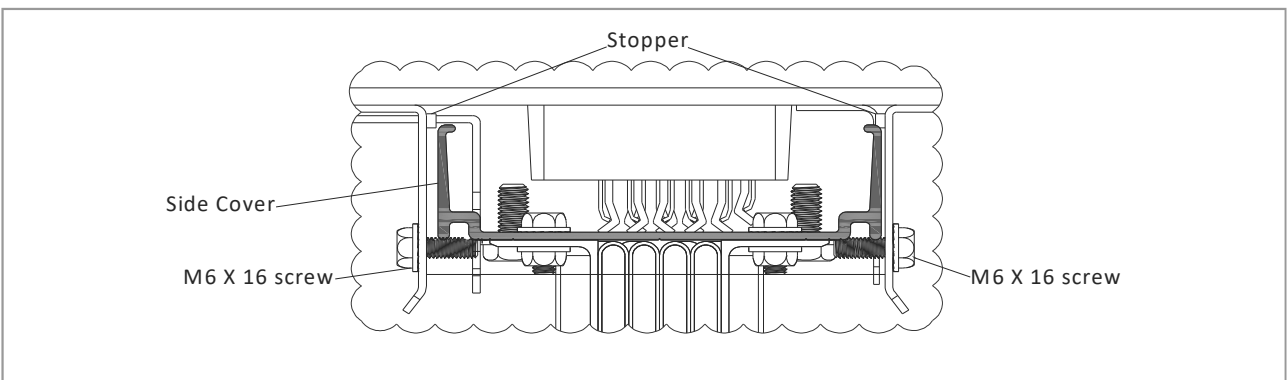

Figure 20.3



Detail "A"

Tap-Off Box Mounting



Installing tap-off unit

12. Push the bottom part of the plug in unit (Figure 21.1)
13. Insert and tighten the M6 x16 screw on the lower part for both side (Figure 21.1)

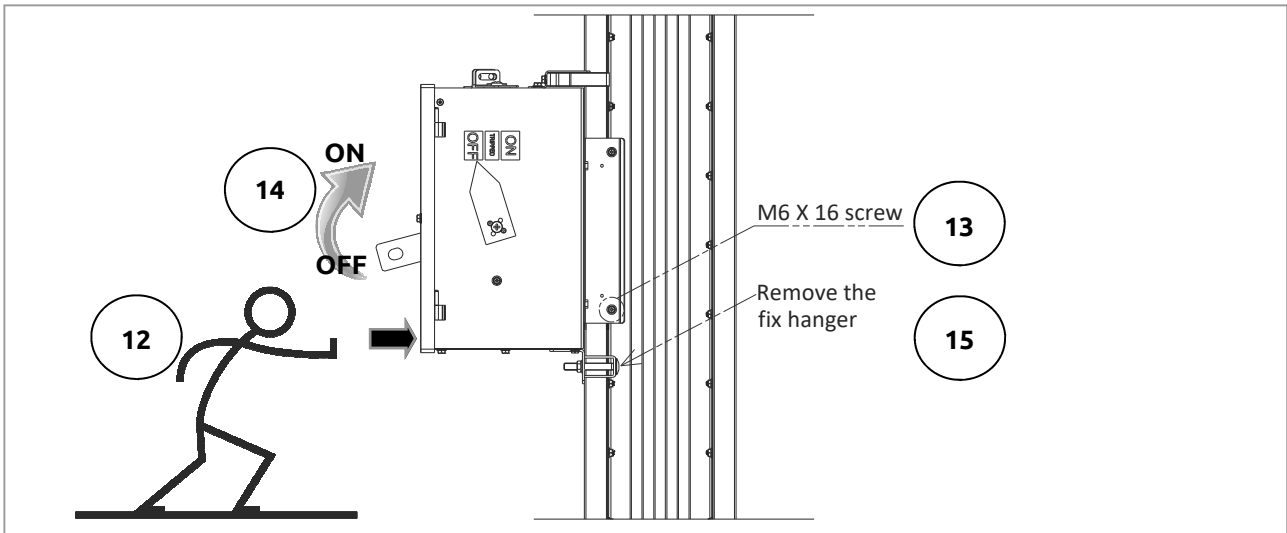

Figure 21.1

14. Test to "ON" and "OFF" the plug in unit so that the switch is smoothly working.
15. Remove the fix hanger at the bottom of the box.

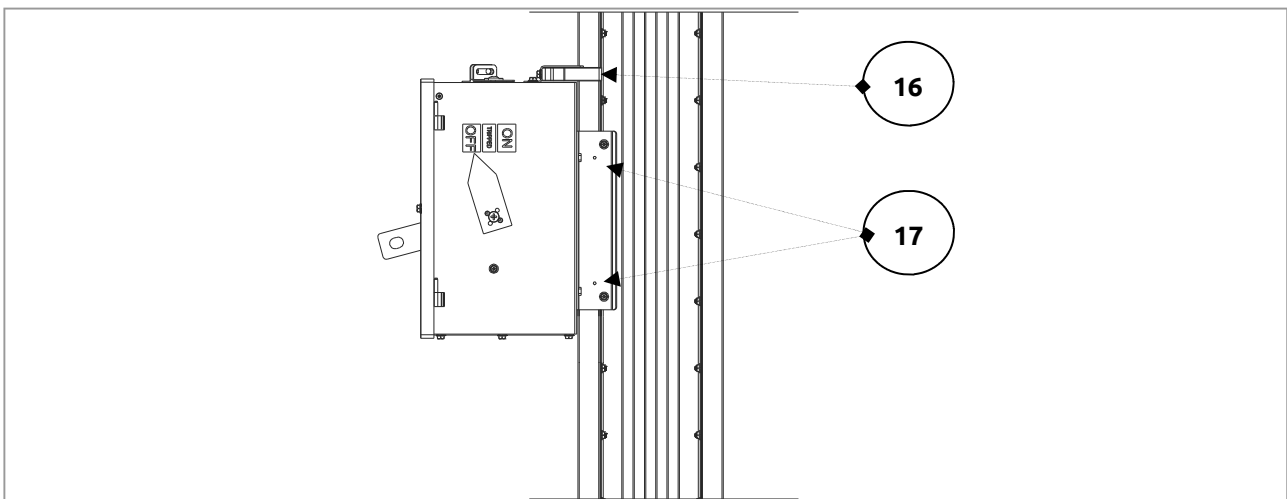

Figure 21.2

16. Tighten the screw on cleat to ensure the box is properly mounted (Figure 21.2).
17. Install the Self Drilling (SD) screw to finish the plug in unit installation process on both side (Use hand tighten force)

Removing tap-off unit

First turn the plug in unit "OFF". Then follow the appropriate procedure above in reverse order.

Tap-Off Box Mounting



Horizontal Mounting

Adding the support on top of unit for horizontal mounting as per Figure 22.1.

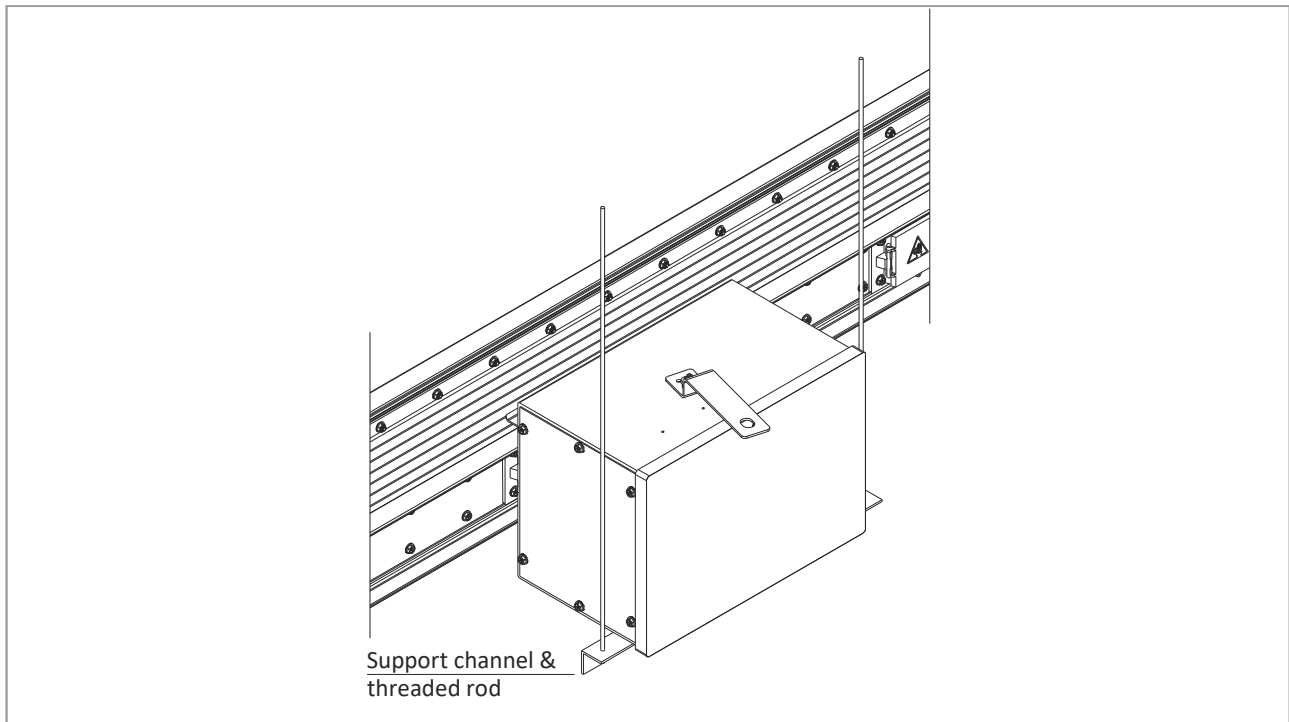



Figure 22.1

Busway Maintenance Procedures



Maintenance Procedures

- ◆ Keep busway free of dust, dirt and/or foreign matter. Moisture from roof leaks or dripping pipes should be eliminated.
- ◆ Inspect the busway system periodically. An infrared thermometer may be used to thermally scan the run to identify potential hot spots.
- ◆ During initial installation, joint bolts are to be tightened until the outer bolt head shears off (approx. 55±5.0 lbs-ft) using the double-headed joint bolt.
- ◆ **Check torque after six months; tighten to 55±5.0 lbs-ft as required. Re-check torque at least annually thereafter.**

 **DANGER**
HAZARD OF ELECTRICAL SHOCK OR BURN. TURN THE POWER TO THE BUSWAY OFF BEFORE INSTALLING, REMOVING, OR WORKING ON THIS EQUIPMENT.

 **WARNING**
ONLY THOSE TRAINED AND QUALIFIED IN RECOGNIZED SAFETY PRACTICES SHOULD PERFORM MAINTENANCE ON THE BUSWAY.

Inspecting Current-Carrying Components

- ◆ Carefully inspect all visible electrical joints and terminations for tightness of bolts, nuts, and other fasteners.
- ◆ Check for signs of overheating at joints, terminations and fuse clips.
- ◆ Check for deterioration in insulating material or melting of sealing compound.
- ◆ Ensure that the condition that caused any overheating has been eliminated.
- ◆ Check for missing or broken parts, proper spring tension, free movement, rust or corrosion, dirt, excessive wear, arc spatter, sooty deposits, and tracking. Clean or replace parts as required.

 **WARNING**
FOR THE FOLLOWING PROCEDURES, THE BUSWAY MUST BE SHUT OFF AND DE-ENERGIZED.

 **WARNING**
FAILURE TO FOLLOW SAFETY PROCEDURES MAY CAUSE PROPERTY DAMAGE, SERIOUS PERSONAL INJURY AND DEATH.

Don't energize the busway before performing any of the following operations.

- ◆ If there are signs of overheating, visually check for deterioration or contamination of insulation and contact surfaces. Check tightness of nuts, bolts, etc.
- ◆ Check for missing or broken parts, corrosion, wear, dirt or signs of arcing. Clean or replace parts as required. After any repair or rework, isolate the busway and megger the busway system. Minimum readings should be no less than:

Mega ohms (MΩ) = 200 / length of run in feet
Mega ohms (MΩ) = 66 / length of run in meters.



Busway Installation Checklist

1. Was there any shipping damage? Report any minor damage or missing parts to the factory. Make sure to include the item number. No

2. Proper storage before actual installation Yes
 - A) Were the busway components kept clean and dry? No
 - B) Were busway components exposed to corrosive fumes, liquids, salts or concrete materials? No

3. Have you read this installation instruction book? Yes

4. Busway exposure during installation. Yes
 - A) Were busway components kept clean and dry? No
 - B) Were busway components exposed to corrosive fumes, liquids, salts or concrete materials? No
 - C) Was there any mechanical damage due to handling? No

5. Did each piece of busway get a pre-installation mega ohm test? (Individual pieces should mega ohm test as infinite resistance. Consult the factory if you experience a lower reading.) Yes

6. Mounting and support Yes
 - A) Is each 10 feet busway run supported, including any vertical sections? (Closer supporting may be required, based on job specifications.) No
 - B) Does any support interfere with busway joint? No
 - C) Are there any busway terminations to other equipment used as support? (Busway weight should not bear on equipment, such as switchgear, switch boards, or transformers.) No

7. Is the busway installed level and plumb? Yes

8. Was a periodic mega ohm test performed as this run was installed? (After every two or three items or as critical items are installed. Joints should be tightened for all mega ohm testing.) Yes

9. Has the busway been inspected for proper phasing? Yes

10. Are all joint bolts properly tightened to 50lb-ft (68 N-m) torque? Yes

11. On vertically mounted busway using spring hangers, were the correct settings verified? (See Figure 7 In the installation instructions.) Yes

12. Did you check for proper clearances for the busway at floors, walls, ceilings, other busway, and trades? (Never use cement to seal between the busway and floors or walls.) Yes

13. Have shipping screws been removed from expansion lengths? Yes

14. Have no rigid hangers been used beyond the free end of expansion lengths (except at the farthest end) to allow the busway to expand toward the expansion box? Yes

15. Was all foreign material removed from the installed busway? Yes

16. Was a final mega ohm test performed when all busway was installed? (Record readings on the separate sheet provided.) Yes

Busway Installation Checklist



- 17. Verify the orientation of weep holes. Are all open weep holes in joint caps, elbows and shields facing downward? (Do not remove shield plugs or weep-hole plugs in top or side positions.) Yes

- 18. Are all drain holes clear in both busway and joint caps? (all construction debris removed.) Yes

- 19. Were joints assembled within the width of the housing ground plates? Yes

- 20. Are joint cap bolts properly tightened to 25 lb-ft (34 N-m)? Yes

- 21. Were shields aligned at the edges of housing ground plates and all springs seated properly? Yes

- 22. Were isolation joints screwed in place before and boxes (when present) were installed? Yes

Notes and comments.

Note: This checklist is intended to insure a sound installation of Powerduct Busway. It is not intended to cover all items related to the installation, successful startup, and long-term use of the product and in no way relieves the contractor of his obligation to meet all specification and code requirement.

Installation Contractor

Signed _____ Dated _____



Busway Installation Checklist

Pre-Energizing Mega ohm Readings

Date	
Run ID	
A-G	
B-G	
C-G	
D-G	
N-G	
A-B	
A-C	
B-C	
A-N	
B-N	
C-N	

Date	
Run ID	
A-G	
B-G	
C-G	
D-G	
N-G	
A-B	
A-C	
B-C	
A-N	
B-N	
C-N	

Date	
Run ID	
A-G	
B-G	
C-G	
D-G	
N-G	
A-B	
A-C	
B-C	
A-N	
B-N	
C-N	

Date	
Run ID	
A-G	
B-G	
C-G	
D-G	
N-G	
A-B	
A-C	
B-C	
A-N	
B-N	
C-N	

Date	
Run ID	
A-G	
B-G	
C-G	
D-G	
N-G	
A-B	
A-C	
B-C	
A-N	
B-N	
C-N	

Date	
Run ID	
A-G	
B-G	
C-G	
D-G	
N-G	
A-B	
A-C	
B-C	
A-N	
B-N	
C-N	

Date	
Run ID	
A-G	
B-G	
C-G	
D-G	
N-G	
A-B	
A-C	
B-C	
A-N	
B-N	
C-N	

Date	
Run ID	
A-G	
B-G	
C-G	
D-G	
N-G	
A-B	
A-C	
B-C	
A-N	
B-N	
C-N	

Date	
Run ID	
A-G	
B-G	
C-G	
D-G	
N-G	
A-B	
A-C	
B-C	
A-N	
B-N	
C-N	

Date	
Run ID	
A-G	
B-G	
C-G	
D-G	
N-G	
A-B	
A-C	
B-C	
A-N	
B-N	
C-N	

Date	
Run ID	
A-G	
B-G	
C-G	
D-G	
N-G	
A-B	
A-C	
B-C	
A-N	
B-N	
C-N	

Date	
Run ID	
A-G	
B-G	
C-G	
D-G	
N-G	
A-B	
A-C	
B-C	
A-N	
B-N	
C-N	

POWERDUCT SERIES BUSWAY

This instruction manual is published solely for information purposes and should not be considered all-inclusive. If further information required, you should consult an authorized PPB sales representative.

The sale of the product shown in this literature is subject to the terms and conditions outlined in appropriate PPB selling policies or other contractual agreement between the parties. This literature is not intended to and does not enlarge or add to any such contract. The sole source governing the rights and remedies of any purchaser of this equipment is the contract between the purchaser and PPB.

NO WARRANTIES, EXPRESSED OR IMPLIED, INCLUDING WARRANTIES OF FITNESS FOR A PARTICULAR PURPOSE OR MERCHANTABILITY, OR WARRANTIES ARISING FROM COURSE OF DEALING OR USAGE OF TRADE, ARE MADE REGARDING THE INFORMATION, RECOMMENDATIONS, AND DESCRIPTIONS CONTAINED HEREIN. In no event will PPB be responsible to the purchaser or user in contract, in tort (including negligence), strict liability or otherwise for any special, indirect, incidental or consequential damage or loss whatsoever, including but not limited to damage or loss of equipment, plant or power system, cost of capital, loss of power, additional expenses in the use of existing power facilities, or claims against the purchaser or user by its customers resulting from use of the information, recommendations and description contained herein.

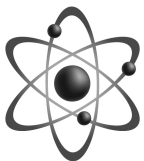

Power Plug Busduct Sdn Bhd (Company No. : 545918-D)

No. 17, Jalan SiLC 1/4,
Kawasan Perindustrian SiLC,
79200 Iskandar Puteri,
Johor, Malaysia

Tel: + 607-532 1988 (Hunting Line)
+ 607-532 1922
+ 607-532 1299
Fax: + 607-532 1177

PPB

www.ppbc.com.my