

POWERDUCT

SERIES

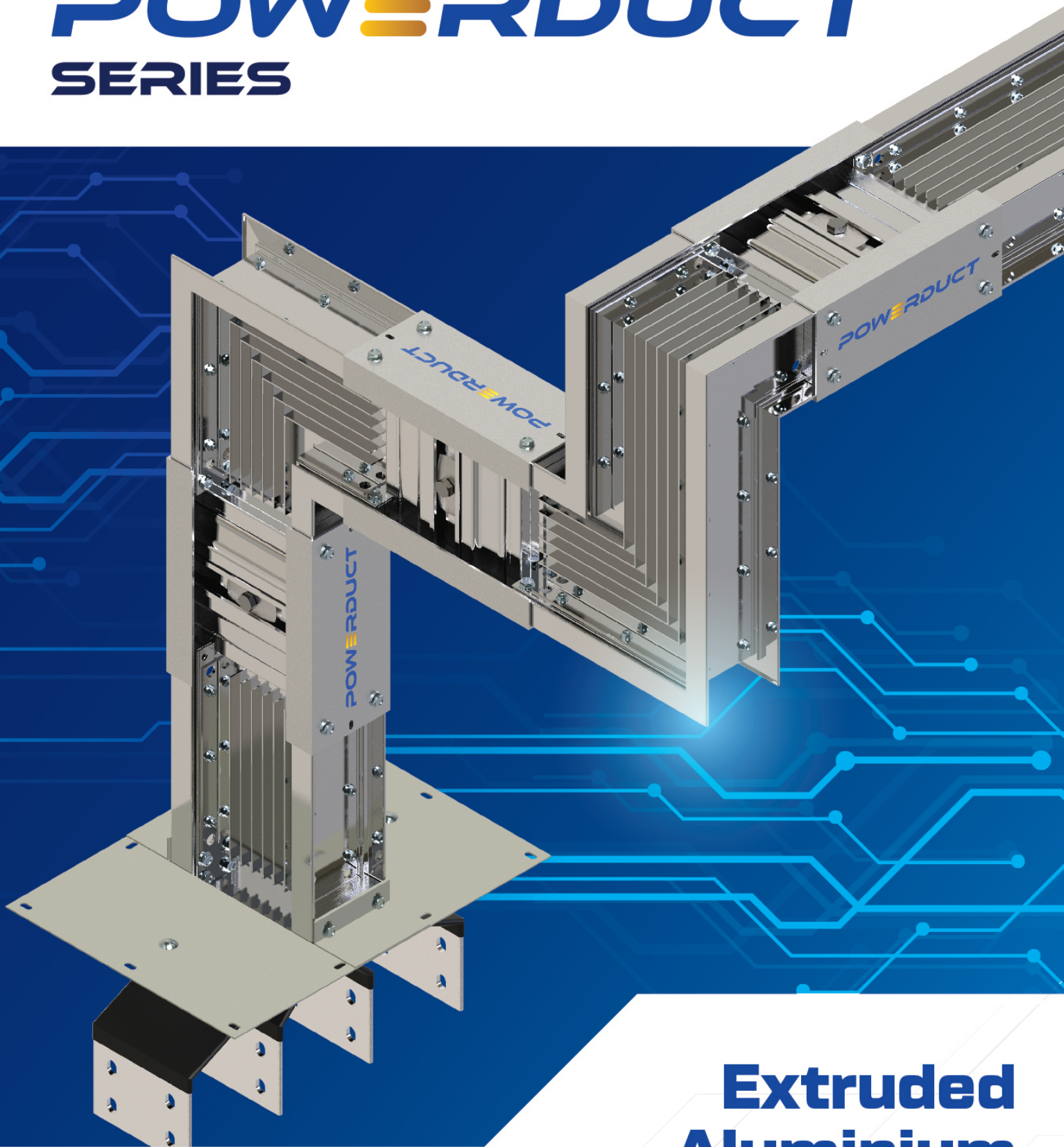

Extruded Aluminium Housing With Cooling Fin

FULLY TYPE TESTED BUSWAY SYSTEM

STAY COMPETENT

Achievement

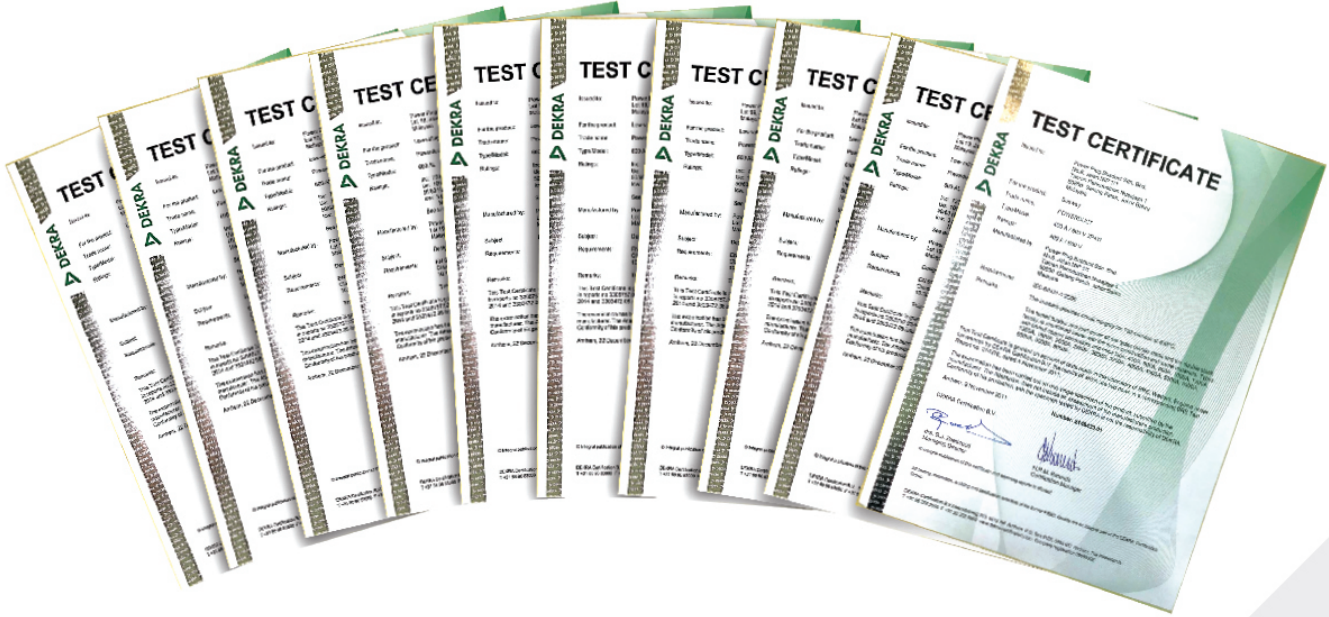

Table Of Content

	Pages
General	1 - 4
Ground Resistance	5
Impedance & Voltage Drop	6
Design & Testing	7
IP Rating	8
Dimension & Weight	9
Physical Data	
• Feeder Section	10
• Plug-in Section	10 - 11
• Elbow & Tee	12
• Offset & Combination Elbow	13
• Reducer & Center Tap Box	14
• End Cable Tap Box	15
• Expansion Fitting	16
• Flanged End	17 - 18
• Plug-in Unit	19 - 21
• Horizontal & Riser Application	22
• Joint Stack	23
• Joint Detail & Feeder Busway Dimension Spacing	24 - 25
• Busway Connection Procedures	26
• Hangers & Floor Support	27 -28
Catalogue Numbering System	29 - 30
Certificate	31
Busway System	32
Job Reference	33 - 34
Fire Rated (FR) System	35

Housing

Powerduct busway is constructed with **extruded** aluminium and is designed with cooling fin on both top and bottom.

Benefits of such design are as follows:

- Super Compact & Light Weight
- Low Impedance
- Greater heat dissipation
- Better housing as Ground medium
- Dust free
- Corrosion free
- Low Installation Cost
- UV resistance

No doubt, this construction has been tested and has achieved the highest 60-cycle short circuit withstand ratings under the IEC and BSEN publication 61439-6 : 2012 approved by third party certification.

The enclosure has also been tested for ingress protection and achieved the highest **IP68** for **standard feeder** and **IP55** for **plug-in section** (ref. Table 8.2).

Hence, this has proved Powerduct housing construction has mechanical strength and its reliability to protect the busbar conductor.

Standard

All the Powerduct busway product is designed and manufactured in compliance of the following standards:

- IEC 60529
- IEC 61439-6
- UL 857
- CSA 857
- CSA C22.9 NO. 27-94
- NEMA BUI
- JIS 8364

Plug in outlet

Powerduct plug in outlets being designed to meet IEC 60529 and IEC 61439-6 and BS EN 60529 requirement whereby the opening safety rated for finger safety to IP2X.

Hinged dead designed at the front of each plug in outlet to protect the contact surfaces from rust, dirt and moisture. Pad lock designed on the outlet to lock the outlet for safety purpose. Gasket is used in IP55.

General

Plug In unit

Available in both moulded case circuit breaker and fusible type;

Powerduct Plug In features the following:

- **Interlocking door** during in 'ON' position to prevent the door from opening for safety purpose
- **Mechanically interlocking** with busway housing during 'ON' position to prevent being take off during energizing.
- The plug-in unit connection on **earth designed to engage first before phase connections** when installing plug-in unit for the safety purpose.
- All Plug In units have internationally recognized symbols indicating the "ON/OFF" position.

Thermal Indicator (optional):

Most of the busway manufacturer will have inspection covers to permit inspection of the joint periodically. However, Powerduct newly designed so call thermal indicator will provide a more convenient for continual visual inspection whereby the thermal indicator will show a sign when the joint is overheating. This benefit from convenience visual inspection without opening the cover and save time from labor inspection.

Before

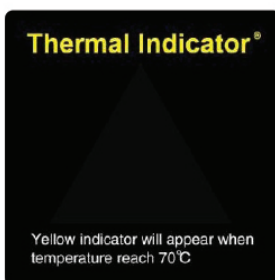

After

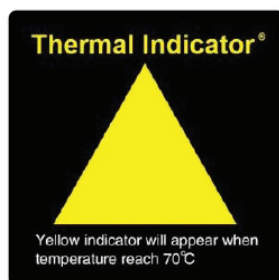

Insulation

The **130°C Class B insulation** is the primary insulation in all conductors. Optional Mylar and epoxy insulation (Hybrid) 155°C Class F and 180°C Class H is available upon customer's request.

The innovated coating process provides high quality and uniform epoxy insulation. This epoxy is nonhygroscopic, self-extinguishing and bonded directly to the bus bar thus eliminating any air gap between the insulation and bus bars.

Advantages of using epoxy insulation are as follows:

- Able to withstand glitch and spikes in electrical system
- Halogen free
- Resistant against water and chemical
- High thermal conductivity
- High mechanical strength against impact and capable with standing heat shock
- Cater for expansion and contraction during peak and off-peak hours
- Long life compare to PVC and Mylar
- Impervious to acids, alkalis, acetones, mechanical oils and lubricants

Joint Stack

Powerduct Joint Stack (bridge type) features a single/multiple bolt design with the double headed bolt, therefore improving the ease and the cost of the installation.

By using this newly designed joint stack, you will definitely reduce arrangement for installation works (on-site time as well as cost saving).

The use of the Belleville spring washers on the bolt ensures the original contact pressure is maintained giving a more secure and reliable joint.

Powerduct Bridge type joint Stack features performs;

- Twin headed Bolts and will shear off when torque exceeds 50lb/ft.
- Single Bolt joint system with the material composition of chrome high tensile steel.
- Ease of removal and installation without removing entire busway section.
- Maintenance Free.

Bus bars

All bus bars copper are manufactured from high electrical grade high conductivity electrolytic coppers which comply with international standard-BS1433/1432. Aluminium bus bars also available.

The copper composition of the bus bar are of 99.9% or conductivity in excess of 99% IACS. The aluminium bus bar are of conductivity in excess of 60% IACS. All the copper and aluminium bus bars are **electroplated** with **tin** on all contact surfaces. Optional **silver plating** is also available. This will improve conductivity more effectively.

All Busway are constructed in sandwich type which means no air gap shall exist between bus bars except at the joint. This can obtain **lower impedance** and **better heat dissipation**. Lower impedance means **lower voltage drop**.

The entire conductor also being insulated with epoxy powder (Hybrid Powder) coated which giving 100% water, rust and chemical resistance. Optional specification can be designed and fabricated to customer's request.

Bus bars are available in various configurations: Refer to next page picture.

1. 3P3W + Integral Ground
2. 3P3W + 50% Internal Ground
3. 3P3W + 100% Neutral + Integral Ground
4. 3P3W + 100% Neutral + 50% Internal Ground
5. 3P3W + 100% Neutral + 100% Internal Ground
6. 3P3W + 200% Neutral + Integral Ground
7. 3P3W + 200% Neutral + 50% Internal Ground
8. 3P3W + 100% Internal Ground

General

True 200% Neutral Construction

Harmonics occur generated by nonlinear load devices such as electronic ballast lighting, computers, printers, copier machines & etc. The harmonic current generated in neutral conductor can be 173% of phase current. This abnormal high neutral current results in overheating the neutral conductor and leads to deterioration of equipment performance and its life cycle.

Therefore, we provide two separate 100% neutral bus bars within the same busway housing. This true 200% neutral is doubling the size of phase bus bars to prevent overheating caused by harmonics.

Bus bar Configurations

1. 3P3W + Integral Ground

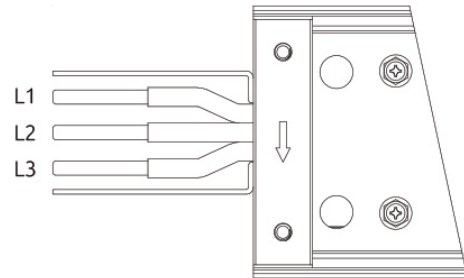

2. 3P3W + 50% Internal Ground

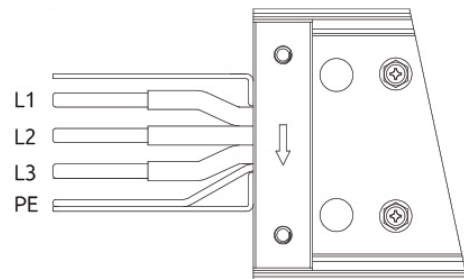

6. 3P3W + 200% Neutral + Integral Ground

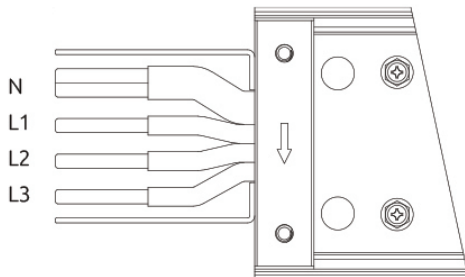

3. 3P3W + 100% Neutral + Integral Ground

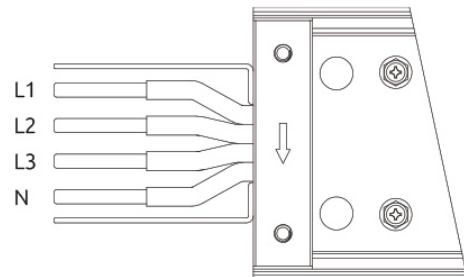

7. 3P3W + 200% Neutral + 50% Internal Ground

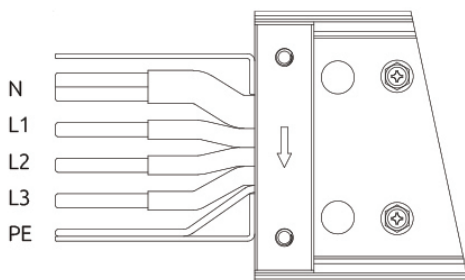

4. 3P3W + 100% Neutral + 50% Internal Ground

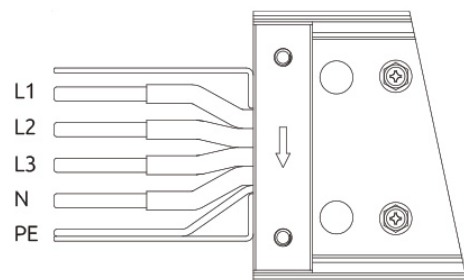

8. 3P3W + 100% Internal Ground

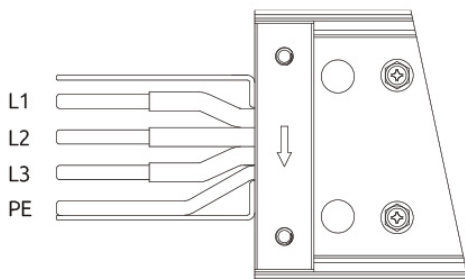

5. 3P3W + 100% Neutral + 100% Internal Ground

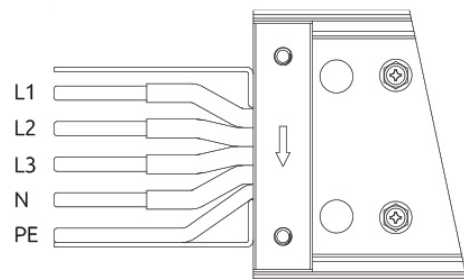

Ground Resistance

Powerduct Busway provides two options of ground capacity:

- Integral aluminium housing ground (standard)
- Copper internal ground

The Powerduct aluminium housing provides extremely high ground capacity. The Table 5.1 showing the conductivity and current carrying capacity offered by the housing is at least 2 times greater than the active copper ground bar (sized 50% of the phase bar)

Powerduct busway-Ground Capacity Table 5.1

Ampere Rating	Aluminium housing Cross Sectional Area integral ground (mm ²)	Bar Sectional Area 50% internal Ground Bar (mm ²)	Capacity Ratio (Integral / Internal)
Copper			
400	1256	58.1	12
600	1296	88.1	8
800	1376	133.1	6
1000	1516	178.1	5
1200	1576	223.1	4
1350	1636	268.1	3
1600	1796	328.1	3
2000	2116	448.1	3
2500	2467	553.1	2
3200	3104	656.2	3
4000	3744	896.2	3
5000	5049	1196.2	2
6300	6899	1794.3	2
Aluminium			
400	1356	118.1	10
600	1356	118.1	10
800	1496	163.1	8
1000	1556	208.1	7
1200	1756	298.1	5
1350	1856	373.1	4
1600	2096	433.1	4
2000	2769	598.1	4
2500	3224	746.3	4
3200	3864	986.3	4
4000	5049	1196.2	4
5000	6899	1794.3	3

Alu Housing Ground Conductivity 55% IACS
 Copper Ground Bar Conductivity 99% IACS
 Alu Ground Bar Conductivity 61% IACS

Energy Optimization

Powerduct busway system enable you to optimize the energy usage and reduce unnecessary energy wastage which is a hidden cost. Better heat dissipation will provide cooler busway energizing. At the same time, the busway has lower impedance and lower voltage drop if compared to the other competitors' busway.

These features also include extremely low reactance due to non-magnetic housing and totally intimate contact of bus bars and housing. Please refer to the Table 6.1 below for your further voltage drop information.

Table 6.1 Voltage Drop Line to Line (50 & 60Hz)

Current Load	Ohms*10 ⁻³ /100m Line to Line			Voltage drop concentrated loads line to line /100M at the rate load, 50°C																							
	R	X	Z	POWER FACTOR																							
				1.000		0.900		0.800		0.700		0.600		0.500		0.400		0.300		0.200		0.100					
				50 Hz	60 Hz	50 Hz	60 Hz	50 Hz	60 Hz	50 Hz	60 Hz	50 Hz	60 Hz	50 Hz	60 Hz	50 Hz	60 Hz	50 Hz	60 Hz	50 Hz	60 Hz	50 Hz	60 Hz				
COPPER																											
400	15.59	3.17	15.91	10.80	10.26	10.68	10.14	9.96	9.46	9.13	8.67	8.24	7.83	7.30	6.94	6.33	6.02	5.34	5.07	4.31	4.10	3.27	3.10				
600	10.42	2.12	10.63	10.83	10.29	10.71	10.17	9.98	9.49	9.15	8.70	8.26	7.85	7.32	6.96	6.35	6.03	5.35	5.08	4.32	4.11	3.28	3.11				
800	6.37	1.56	6.56	8.83	8.39	8.89	8.44	8.36	7.94	7.72	7.34	7.03	6.67	6.29	5.97	5.51	5.24	4.71	4.47	3.88	3.69	3.03	2.88				
1000	4.78	1.18	4.92	8.28	7.87	8.34	7.93	7.85	7.46	7.26	6.89	6.60	6.27	5.91	5.61	5.18	4.93	4.43	4.21	3.66	3.48	2.86	2.72				
1200	3.82	0.97	3.94	7.94	7.54	8.02	7.62	7.56	7.18	7.00	6.65	6.38	6.06	5.72	5.43	5.02	4.77	4.31	4.09	3.56	3.39	2.80	2.66				
1350	3.19	0.82	3.29	7.46	7.09	7.55	7.17	7.12	6.76	6.59	6.26	6.01	5.71	5.39	5.12	4.74	4.50	4.07	3.86	3.37	3.20	2.65	2.52				
1600	2.61	0.69	2.70	7.23	6.87	7.34	6.98	6.93	6.59	6.43	6.11	5.87	5.58	5.27	5.01	4.65	4.41	3.99	3.79	3.32	3.15	2.63	2.49				
2000	1.91	0.53	1.98	6.62	6.29	6.76	6.42	6.39	6.07	5.94	5.65	5.44	5.17	4.90	4.65	4.33	4.11	3.74	3.55	3.12	2.97	2.49	2.36				
2500	1.55	0.44	1.61	6.71	6.38	6.87	6.53	6.51	6.19	6.06	5.76	5.55	5.27	5.01	4.76	4.43	4.21	3.83	3.64	3.21	3.05	2.57	2.44				
3200	1.30	0.39	1.36	7.21	6.85	7.43	7.06	7.06	6.71	6.59	6.26	6.05	5.75	5.47	5.20	4.86	4.62	4.22	4.01	3.56	3.38	2.87	2.73				
4000	0.96	0.29	1.00	6.65	6.32	6.86	6.52	6.53	6.20	6.09	5.79	5.60	5.32	5.07	4.81	4.50	4.28	3.91	3.72	3.30	3.13	2.66	2.53				
5000	0.72	0.24	0.76	6.24	5.92	6.52	6.19	6.24	5.92	5.85	5.56	5.40	5.13	4.92	4.67	4.40	4.18	3.85	3.66	3.28	3.12	2.69	2.56				
6300	0.50	0.12	0.51	5.46	5.18	5.48	5.21	5.15	4.89	4.75	4.52	4.32	4.11	3.86	3.67	3.38	3.21	2.89	2.74	2.37	2.26	1.85	1.76				
ALUMINIUM																											
400	11.21	2.56	11.50	7.77	7.38	7.76	7.37	7.28	6.91	6.70	6.37	6.08	5.77	5.42	5.15	4.73	4.50	4.02	3.82	3.29	3.13	2.54	2.41				
600	11.21	2.56	11.50	11.65	11.07	11.64	11.06	10.92	10.37	10.05	9.55	9.12	8.66	8.13	7.72	7.10	6.74	6.03	5.73	4.94	4.69	3.81	3.62				
800	8.11	1.65	8.28	11.24	10.68	11.11	10.55	10.36	9.84	9.50	9.02	8.57	8.14	7.60	7.22	6.59	6.26	5.55	5.27	4.49	4.26	3.40	3.23				
1000	5.46	1.32	5.62	9.46	8.98	9.51	9.03	8.94	8.49	8.25	7.84	7.50	7.13	6.71	6.37	5.88	5.58	5.02	4.77	4.13	3.92	3.22	3.06				
1200	4.82	1.20	4.97	10.02	9.52	10.10	9.60	9.51	9.04	8.79	8.35	8.01	7.61	7.17	6.81	6.29	5.98	5.38	5.12	4.45	4.23	3.48	3.31				
1350	3.51	0.82	3.60	8.21	7.80	8.22	7.81	7.72	7.33	7.11	6.76	6.46	6.14	5.76	5.48	5.04	4.79	4.29	4.08	3.52	3.34	2.73	2.59				
1600	3.32	0.68	3.39	9.20	8.74	9.10	8.65	8.49	8.07	7.79	7.40	7.03	6.68	6.23	5.92	5.41	5.14	4.56	4.33	3.69	3.50	2.80	2.66				
2000	2.38	0.64	2.46	8.24	7.83	8.39	7.97	7.93	7.53	7.35	6.99	6.72	6.38	6.04	5.74	5.33	5.06	4.59	4.36	3.82	3.63	3.03	2.88				
2500	2.22	0.46	2.27	9.61	9.13	9.52	9.04	8.89	8.44	8.15	7.74	7.36	6.99	6.53	6.20	5.67	5.39	4.78	4.54	3.87	3.68	2.94	2.80				
3200	1.44	0.42	1.50	7.98	7.58	8.20	7.79	7.78	7.39	7.25	6.89	6.65	6.32	6.01	5.71	5.33	5.06	4.62	4.38	3.88	3.68	3.11	2.96				
4000	1.19	0.36	1.24	8.24	7.83	8.51	8.08	8.09	7.69	7.55	7.17	6.94	6.59	6.28	5.97	5.58	5.30	4.85	4.61	4.09	3.89	3.31	3.14				
5000	1.17	0.24	1.19	10.13	9.63	10.03	9.52	9.35	8.89	8.58	8.15	7.74	7.36	6.87	6.52	5.96	5.66	5.02	4.77	4.06	3.86	3.08	2.93				

Note: Current density (amps/sq.in) rated busway available. Consult Factory Voltage Drop Formula

1. Plug-in distributed loads application, divide voltage drop values by 2
2. To determine voltage drop line to neutral, multiply values from table by 0.577.
3. Actual voltage drop for different length and at loading less than full rated current can be calculated by using the formula :
 $V_d = V_d(\text{table}) \times \text{Actual load} / \text{Rated load} \times \text{Actual length (m)} / 100 \text{ m}$
4. For 400Hz, Multiply reactance by 3.75 and multiply resistance by 1.4
5. Calculate new voltage drop : $V_d = \text{Amp loads} \times \sqrt{3} \times (R \cos \phi + X \sin \phi)$ per 100m, where $\cos \phi = \text{Power Factor}$

Design & Testing

Short Circuit Protection and Capacity

Powerduct structure is designed to provide a very good short circuit protection. The short circuit has been certified by DEKRA (formerly known as KEMA) in accordance with IEC and BSEN Publication 61439-6.

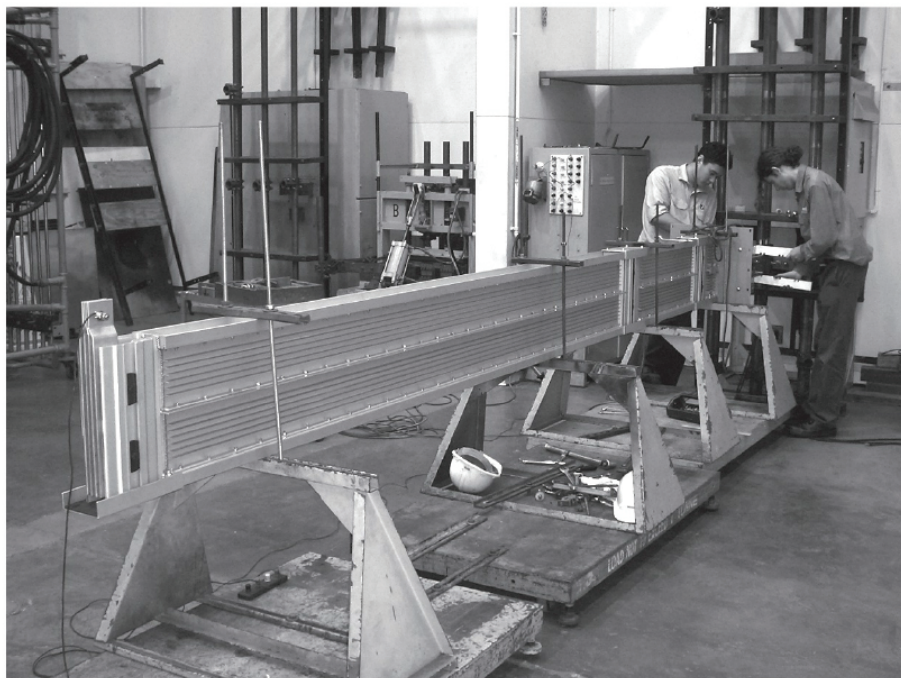

Temperature Rise

Powerduct busway is capable of carrying its full rated current continuously in ambient condition of 95% relative humidity and maximum temperature of 50°C without exceeding 55°C temperature rise.

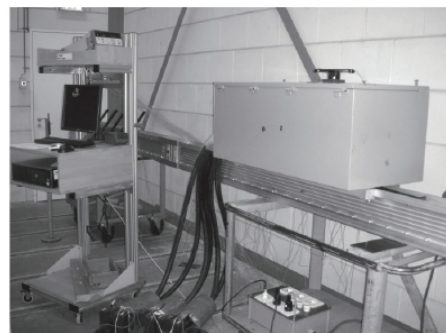

Thermal cycling test

Powerduct tested to ambient 50°C test

Extract from KEMA Newsletter:

Busduct beats the heat in 50 °C test
 High-temperature test opens up new markets for Power Plug Busduct Tested to IEC60439-2

When many manufacturers of electrical gear in the Middle East are pushing the envelope in testing to make sure their products can withstand the extreme temperatures in the region, thanks to the KEMA high-temperature test, the Malaysian company Power Plug Busduct sdn bhd, whose products had already undergone KEMA type testing according to the international standard, can be confident that their power ducts will provide unwavering performance at 50 °C. High Temperature requirements

KEMA's Henk Kormelink says, "A bus duct tested according to the standard complies to a mean ambient air temperature of less than or equal to 35 °C (IEC 60439-2 international standard). However, day time temperatures in the Middle East often exceed 50 °C. It was particularly important for this client to have their product tested at the most extreme temperatures, because many of their products carry high-voltage cables that are placed in uncooled areas of buildings. These ducts must continue to operate safely at the very highest temperatures and customers cannot afford failures."

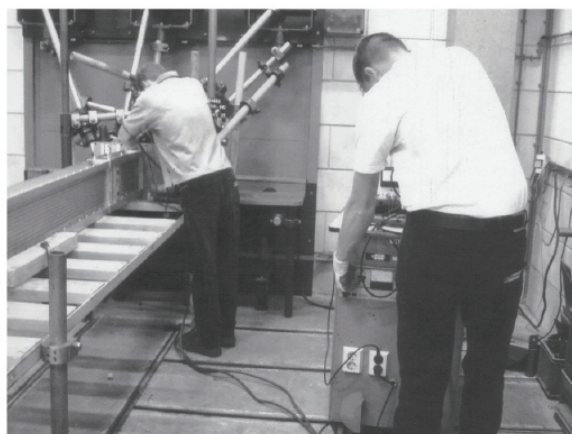

IP Rating

Ingress Protection Level

Water Resistance and Rust Protection : Powerduct busway system has been successfully developed into as high as IP68, whereby the busway is protected against dust and the effects of immersion in water. This fine completion system is in 100% compliance IEC standards and is approved through third party authority certification.

Table 8.1

Busway Type	DEGREE OF PROTECTION						
	IP40	IP54	IP55	IP65	IP66	IP67	IP68
Feeder	X	X	X	X	X	X	X
Plug-in	X	X	X				
Plug-in Units	X	X	X				

Note: All Powerduct plug-in busway is IP 2x rated. (Finger Safe Plug-in outlets)

Table 8.2

Degree of Protection	IEC 60529-Level of Protection
	Description
IP2x	Protection against objects greater than 12mm.
IP40	Enclosure protects against objects greater than 1mm. Indoor application <u>Indoor</u>
IP54	Enclosure is dust protected and splashed water. <u>Indoor</u>
IP55	Enclosure is dust protected and splayed water. <u>Indoor</u>
IP65	Enclosure is dust tight and splayed water. <u>Indoor</u>
IP66	Enclosure is dust tight and protects against heavy jets. <u>Indoor/Outdoor</u>
IP67	Enclosure is dust tight and protects against effects of immersion up to 1 meter. <u>Outdoor</u>
IP68	Enclosure is dust tight and protects against effects of immersion beyond 1 meter. <u>Outdoor</u>

Dimension & Weight

Table 9.1

Ampere Rating	Figure no.	Dimension in mm "W"	Approximate weight (kg/3Meter)					
			TP only	TP w/ground bar	TP & 100%N	TP & 100%N w/ground bar	TP& 200%N	TP & 200%N w/ground bar
COPPER								
400	9.1	89	24	26	28	30	31	33
600	9.1	99	29	32	35	38	40	42
800	9.1	114	37	41	45	48	52	56
1000	9.1	129	41	46	50	55	59	63
1200	9.1	144	46	54	68	74	80	86
1350	9.1	159	56	63	78	86	92	101
1600	9.1	179	65	74	93	103	111	120
2000	9.1	219	98	110	123	136	147	160
2500	9.1	254	119	134	150	166	188	205
3200	9.2	295	141	160	178	197	223	243
4000	9.2	375	188	213	239	264	288	313
5000	9.2	475	250	283	318	351	383	416
6300	9.3	681	371	420	473	523	572	621
ALUMINIUM								
400	9.1	109	19	20	21	22	24	25
600	9.1	109	19	20	21	22	24	25
800	9.1	124	23	25	26	28	29	31
1000	9.1	139	26	28	30	32	34	36
1200	9.1	169	33	36	39	42	44	47
1350	9.1	194	38	42	45	49	52	56
1600	9.1	214	44	48	52	56	60	64
2000	9.1	269	58	63	68	73	78	84
2500	9.2	325	72	79	86	93	100	107
3200	9.2	405	87	96	105	114	123	132
4000	9.2	475	109	119	129	139	140	151
5000	9.3	681	174	204	219	234	249	267

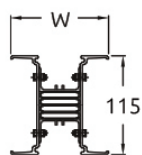

Fig. 9.1

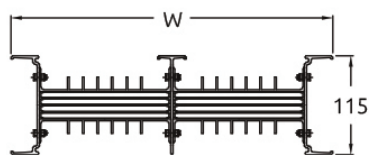

Fig. 9.2

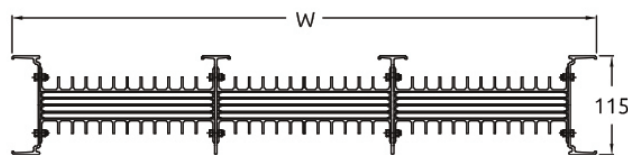

Fig. 9.3

Physical Data

Feeder Section – is available in standard length of 3050mm and with minimum 610mm. This straight length feeder is used to carry power supply directly to the machine and power station without any plug-in opening on the section. (Concentrated Load application) Refer to the Fig. 10.1

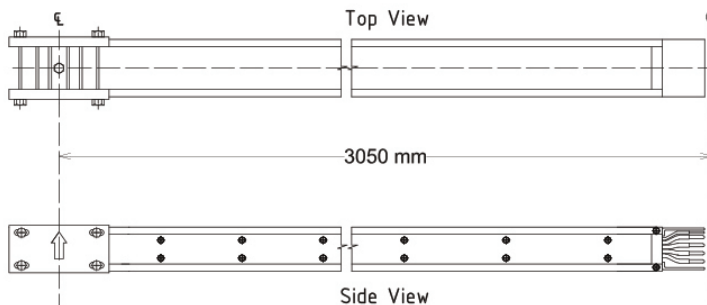

Fig 10.1 Standard feeder Section - Top and Side Views

Plug-in section – is designed to provide convenience and to allow the power to be tapped off from the LIVE busway section for a variety power usage based on the customer’s requirement. It is complement with the plug-in unit. The maximum current capacity of each opening is 400A. Refer Fig.10.2

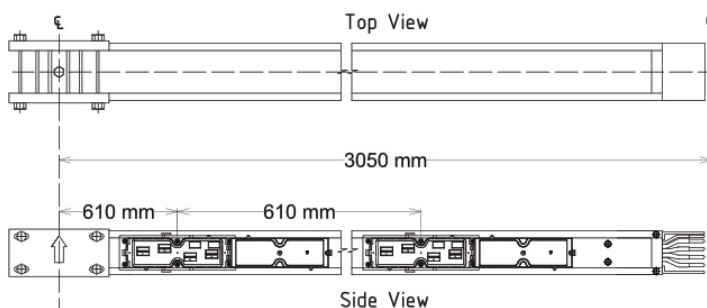

Fig 10.2 Standard Plug-in Section - Top and Side Views

Physical Data

Plug-In Section

Plug-In Section is available in minimum 1220mm and standard 3050mm length rating from 400A to 5000A. Custom length also is available on request.

The quantity of plug-in outlet is classified into:

Standard plug-in busway – whereas the openings outlet available in both sides to optimize the amount of plug-in units in horizontal application . Fig.11.1 (Optional 5 holes is available upon request. Please consult factory)

Riser – whereas opening outlet available in one side on interval 610mm to fit the vertical runs. Fig.11.2

Limited Access – whereas customized design. Plug-in outlet can be placed upon customer request. Fig.11.3

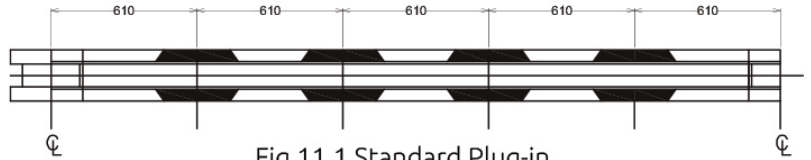

Fig 11.1 Standard Plug-in

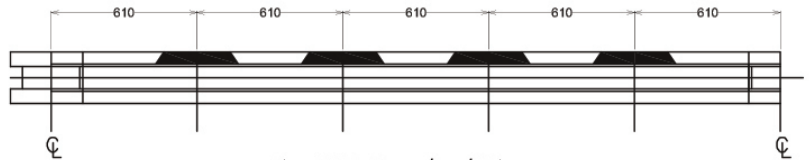

Fig 11.2 Standard Riser

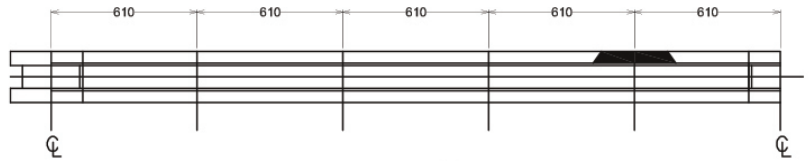
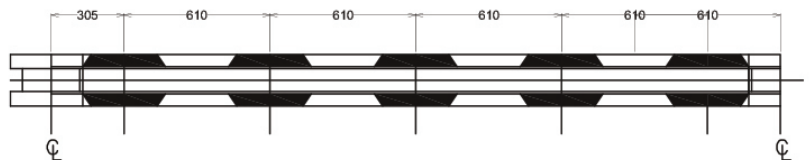

Fig 11.3 Limited Access



Optional 5 holes is available upon request (please consult factory).

Standard Plug-in Outlet

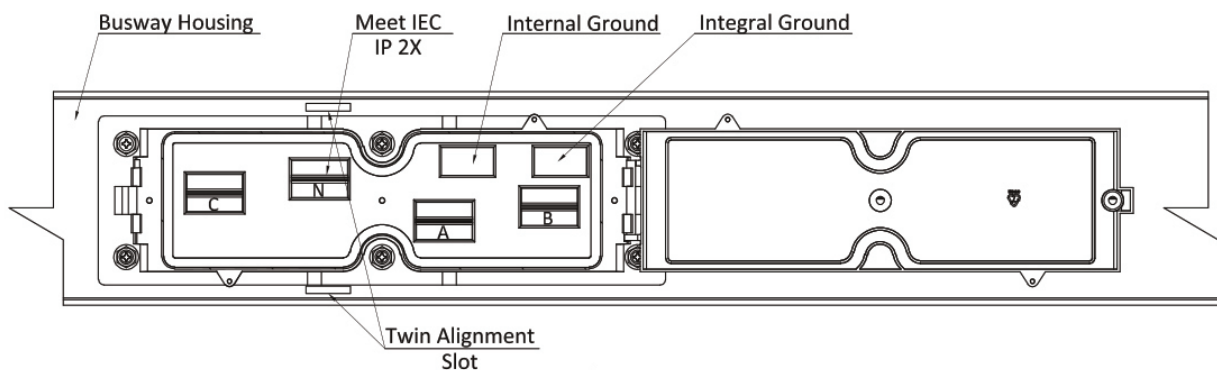
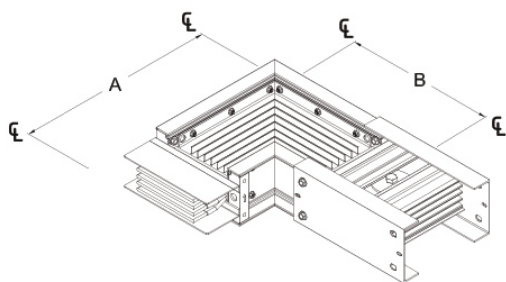

Fig. 11.4

Physical Data

Flatwise Elbow



Edgewise Elbow

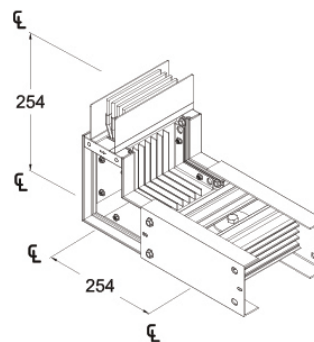

Current Rating (Copper)	Current Rating (Aluminium)	Standard Length (mm)	
		A	B
400 ~ 1600	400 ~ 1200	305	305
2000 ~ 4000	1350 ~ 3200	457	457
5000 ~ 6300	4000 ~ 5000	610	610

Flatwise Tees

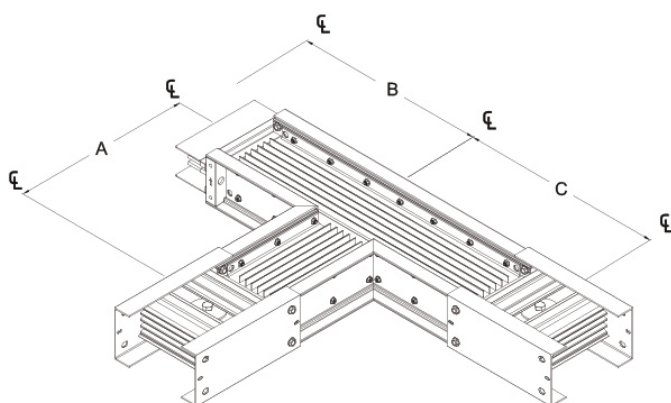

Edgewise Tees

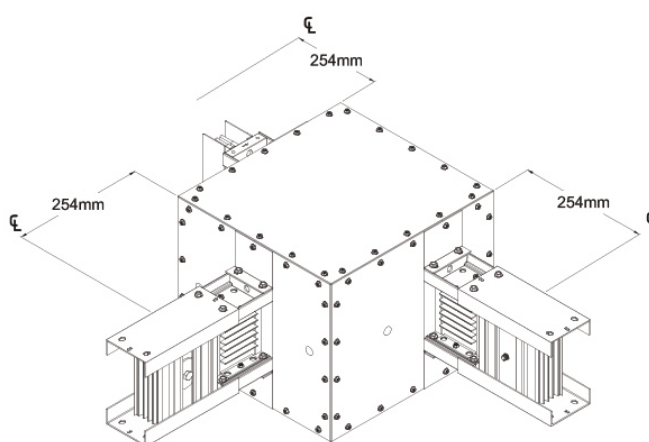

* Note:
Please consult factory for the above dimension

Current Rating (Copper)	Current Rating (Aluminium)	Standard Length (mm)		
		A	B	C
400 ~ 1600	400 ~ 1200	305	305	305
2000 ~ 4000	1350 ~ 3200	457	457	457
5000 ~ 6300	4000 ~ 5000	610	610	610

Physical Data

Flatwise Offset

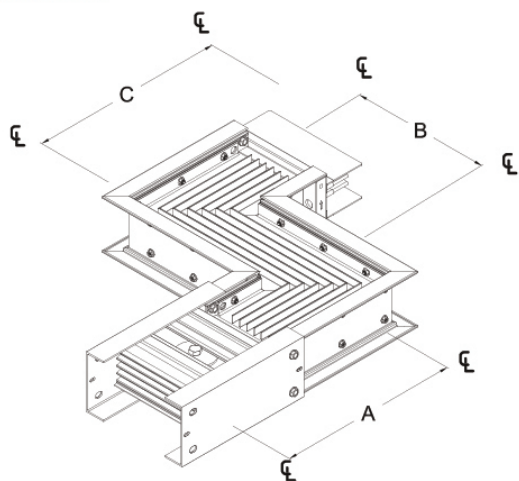

Edgewise Offset

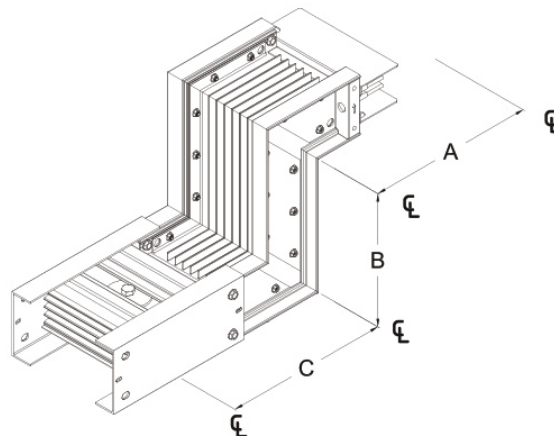

Current Rating (Copper)	Current Rating (Aluminium)	Standard Length (mm)		
		A	B	C
400 ~ 1600	400 ~ 1200	305	305	305
2000 ~ 4000	1350 ~ 3200	457	457	457
5000 ~ 6300	4000 ~ 5000	610	610	610

Current Rating (Copper)	Current Rating (Aluminium)	Standard Length (mm)		
		A	B	C
400 ~ 1600	400 ~ 1200	254	254	254
2000 ~ 4000	1350 ~ 3200	254	254	254
5000 ~ 6300	4000 ~ 5000	254	254	254

Combination Elbow

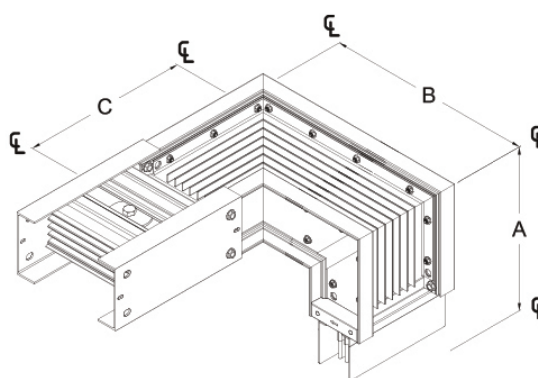
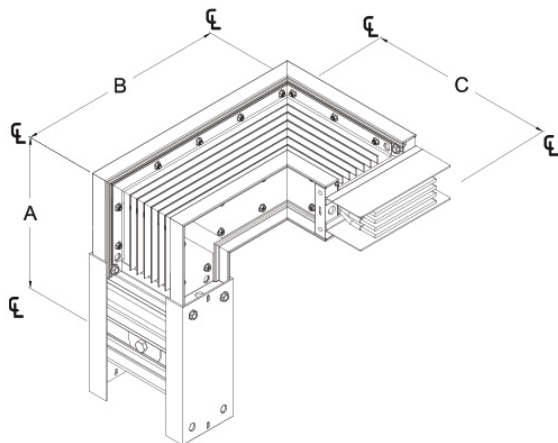

Current Rating (Copper)	Current Rating (Aluminium)	Standard Length (mm)		
		A	B	C
400 ~ 1600	400 ~ 1200	254	305	305
2000 ~ 4000	1350 ~ 3200	254	457	457
5000 ~ 6300	4000 ~ 5000	254	610	610

Physical Data

Reducer

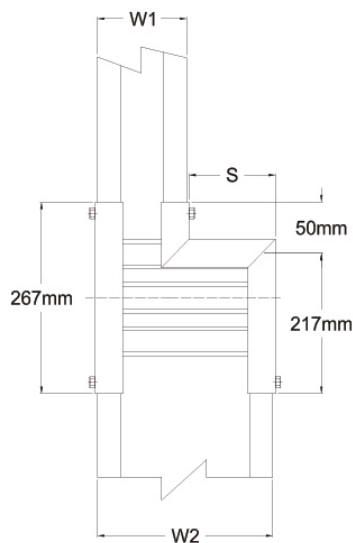
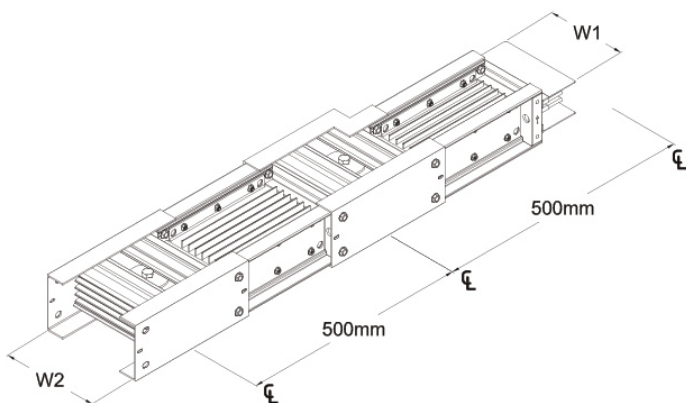

Table 14.1

Ampere Rating (Copper)	W1 (mm)	W2 (mm)	S (mm)
600	89	99	10
800	99	114	15
1000	114	129	15
1200	129	144	15
1350	144	159	15
1600	159	179	20
2000	179	219	40
2500	219	254	35
3200	254	295	41
4000	295	375	80
5000	375	475	100
6300	475	681	206

Ampere Rating (Aluminium)	W1 (mm)	W2 (mm)	S (mm)
800	109	124	15
1000	124	139	15
1200	139	169	30
1350	169	194	25
1600	194	214	20
2000	214	269	55
2500	269	325	56
3200	325	405	80
4000	405	475	70
5000	475	681	206

* Optional Reducer with MCCB / Fusible breaker is available. Please consult factory.

Center Tap Box

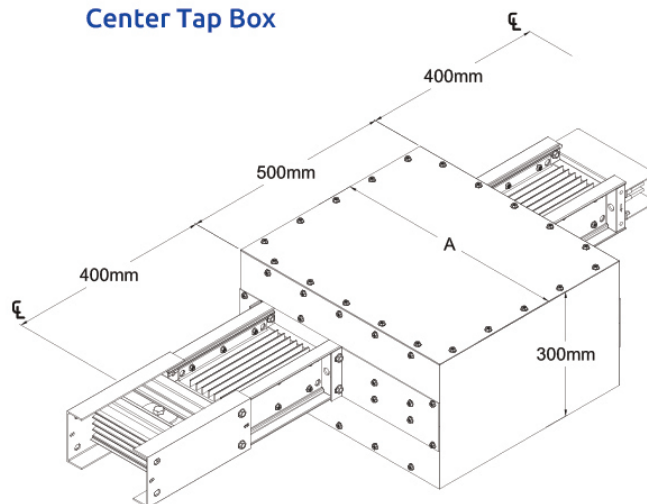

Center Tap Box is a device that is non-fusible utilized to take off power from the busway run. It is used in the condition when loads served by the busway run do not require over-current protection. Refer the Table 14.2 for the dimension in (mm).

Table 14.2

Current Rating (Copper)	Current Rating (Aluminium)	Dimension 'A' in (mm)
400 ~ 1350	400 ~ 1000	405
1600 ~ 2500	1200 ~ 2000	555
3200 ~ 5000	2500 ~ 4000	725
6300	5000	930

* Optional Center Tap Box with MCCB / Fusible breaker is available. Please consult factory.

Physical Data

End Cable Tap Box

End Tap Box are non-fusible devices used to connect cable and conduit to the end of the busway run or where busway runs connect without the need for over current protection.

Table 15.1

Current Rating (Copper)	Current Rating (Aluminium)	Standard Length (mm)		
		A	B	C
400 ~ 1350	400 ~ 1000	290	525	285
1600 ~ 2500	1200 ~ 2000	390	625	385
3200 ~ 5000	2500 ~ 4000	570	675	435
6300	5000	780	725	485

* Optional End Cable Tap Box with MCCB / Fusible breaker is available. Please consult factory.

Vertical Application

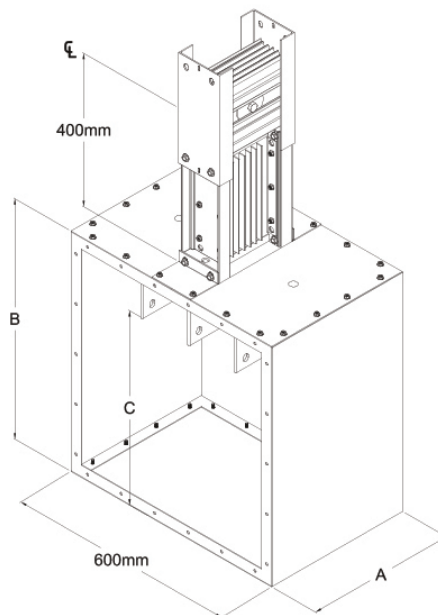

Fig. 15.1

Table 15.2

Current Rating (Copper)	Current Rating (Aluminium)	Standard Length (mm)		
		A	B	C
400 ~ 1350	400 ~ 1000	290	379	135
1600 ~ 2500	1200 ~ 2000	390	429	185
3200 ~ 5000	2500 ~ 4000	570	479	235
6300	5000	780	529	285

* Optional End Cable Tap Box with MCCB / Fusible breaker is available. Please consult factory.

Horizontal Application

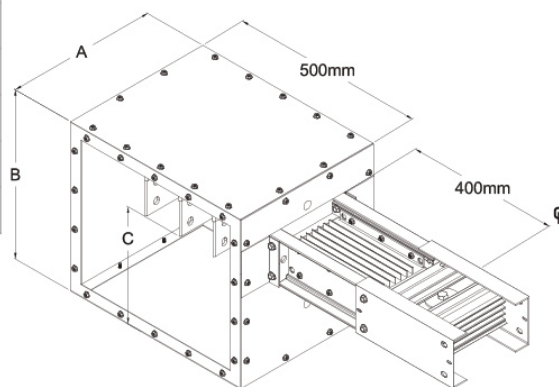

Fig. 15.2

Physical Data

Expansion Fitting

Powerduct Expansion Fitting is design to accommodate the busway thermal expansion in long straight runs which is over 60.8M without offsets or elbows and spring hanger are included and both ends are held fixed, or in a permanent position. In addition, it is also recommended when the busway crosses the building expansion joint.

Inside the Powerduct Expansion Fitting contains a flexible connector which provides + 50mm linear movement along the straight busway system.

Table 16.1

Current Rating (Copper)	Current Rating (Aluminium)	Dimension "W" in (mm)
400 ~ 1350	400 ~ 1000	300
1600 ~ 2500	1200 ~ 2000	400
3200 ~ 5000	2500 ~ 4000	600
6300	5000	810

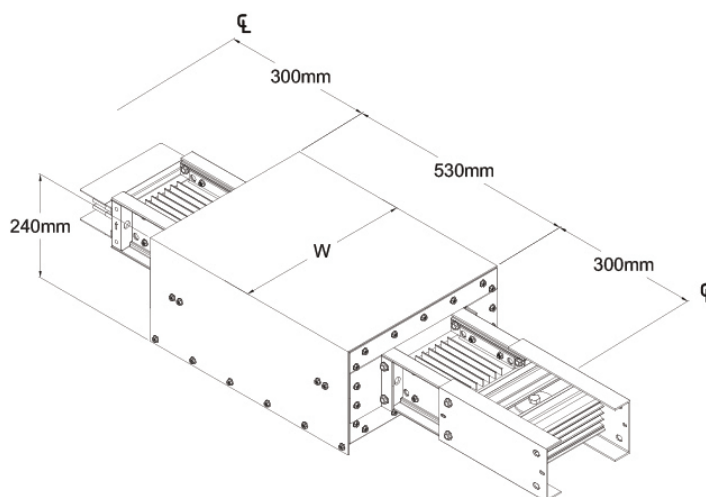

Fig. 16.1

Physical Data

Flanged End

Flanged End provides the connection between busway and the low voltage switch board, control panel or other distribution system.

Right Edge Elbow With Flanged End

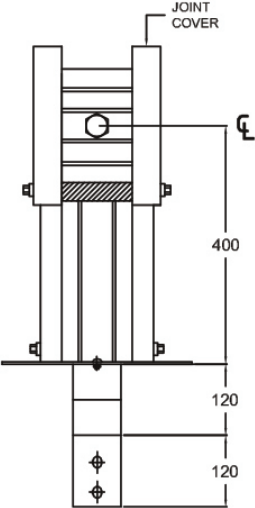
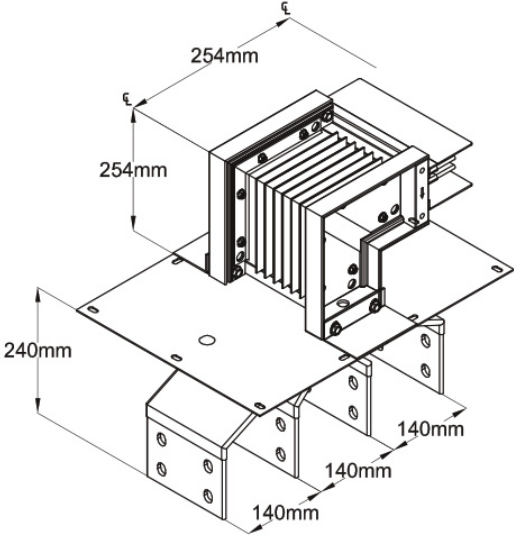
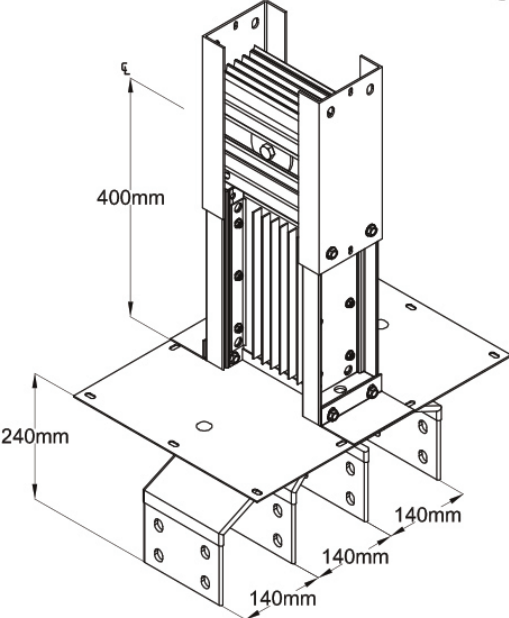

Case and Bars
One Bar Per Phase

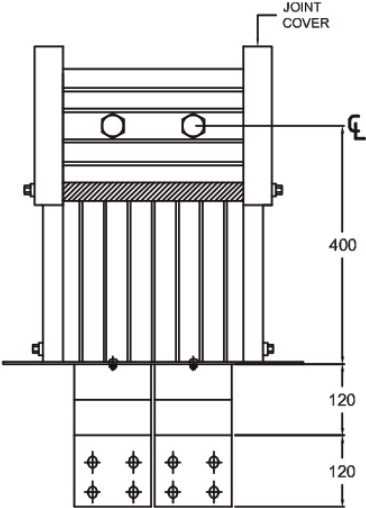

Case and Bars
Two Bar Per Phase

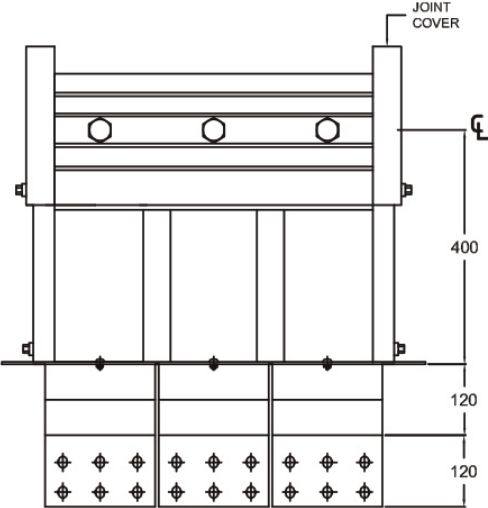

Case and Bars
Three Bar Per Phase

Physical Data

Flanged End Cut Out and Drilling Pattern

Copper Ampere	Dimensions in mm			Fig. no.
	A	B	C	
400	260	200	114	18.1
600	260	200	114	18.1
800	260	200	114	18.1
1000	260	200	114	18.1
1200	260	200	114	18.1
1350	260	200	114	18.1
1600	354	294	161	18.1
2000	354	294	161	18.1
2500	354	294	161	18.1
3200	476	416	110	18.2
4000	476	416	110	18.2
5000	546	486	128.5	18.2
6300	770	710	123	18.3

Aluminium Ampere	Dimensions in mm			Fig. no.
	A	B	C	
400	260	200	114	18.1
600	260	200	114	18.1
800	260	200	114	18.1
1000	260	200	114	18.1
1200	354	294	161	18.1
1350	354	294	161	18.1
1600	354	294	161	18.1
2000	354	294	161	18.1
2500	476	416	110	18.2
3200	546	486	128.5	18.2
4000	546	486	128.5	18.2
5000	770	710	123	18.3

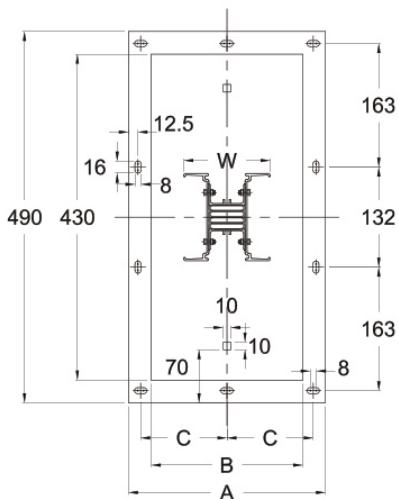

Fig. 18.1

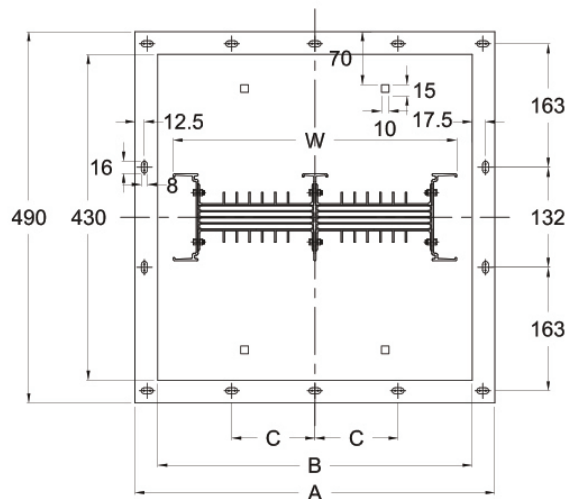

Fig. 18.2

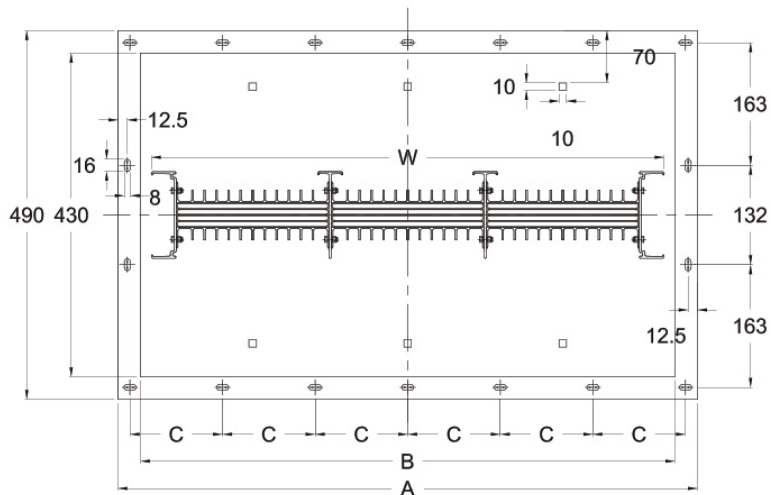

Fig. 18.3

Physical Data

Plug-in Unit

Powerduct plug-in unit is available from rating 15A to 800A with different levels of fault protection. A maximum ten pieces of 400A (max) plug-in unit ≤ can be mounted on a standard 3050mm plug-in busway. The **maximum** amperage carried by **each plug-in opening is 400A**. Therefore, 500A ~ 800A will accommodate two openings.

Safety Features:

Powerduct plug-in unit features mechanical interlock system. This is to prevent the insertion or removal when the plug-in unit is in "ON" position (energizing). (Fig. 19.2)

The front operating switch allows padlocking at the "OFF" position. This is to prevent switching to "ON" accidentally during servicing and maintenance. The plug-in earth contact is being designed so that the earth contact is made prior contact to the LIVE busway during installation. Besides, it also features water resistant capability to suit customers' need. The plug-in unit is rated from IP40 as standard but customers can order IP55 as optional.

Refer to the Table 19.1 for the sizes availability of the unit with ampere rating.

Table 19.1 Plug-in dimension

Ampere rating	Dimension mm		
	H	W	D
15 ~ 100	380	270	240
125 ~ 250	480	270	240
300 ~ 400	580	270	270
500 ~ 630	1060	480	380
700 ~ 800	1060	480	420

* For above 1000A, please consult factory

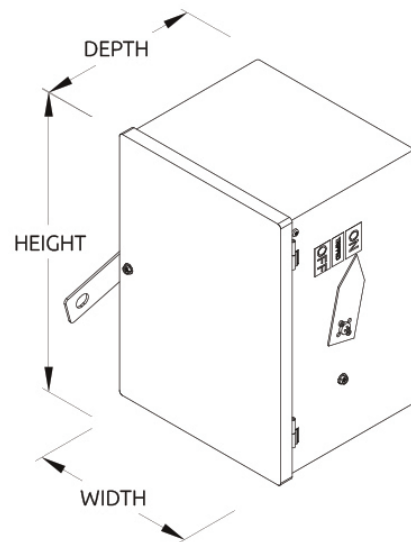

Fig. 19.1

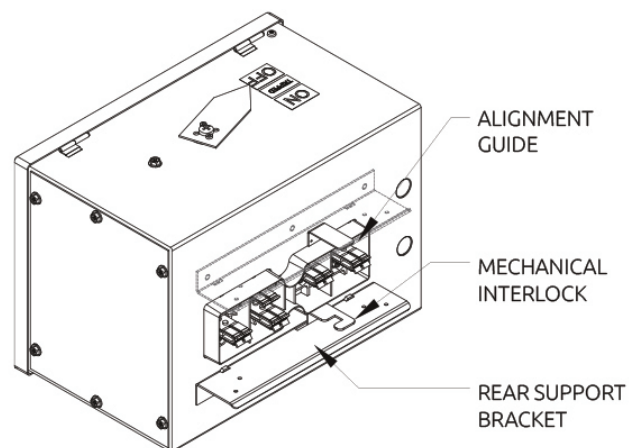

Fig. 19.2

Physical Data

Plug In Unit

Safety Lock

Door Interlock– plug in door locked soon the operating switch is 'ON' position.

Mechanical Interlock with Busway Housing-The plug in cannot be attached or detached from the busway when the operating switch is 'ON'

Knock-out Hole

No knock-out hole is provided. Make it at site in conformity with the cable size.

Grounding

Plug in enclosures shall make positive ground connection to the busway housing prior to the bus bar contact.

Plug In unit Dimensions

Front View
(15A ~ 400A)

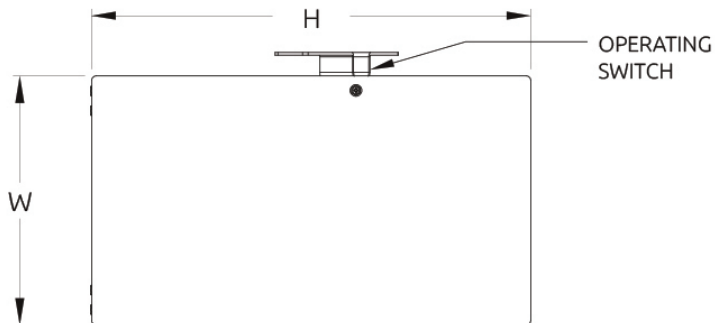

Side View
(15A ~ 400A)

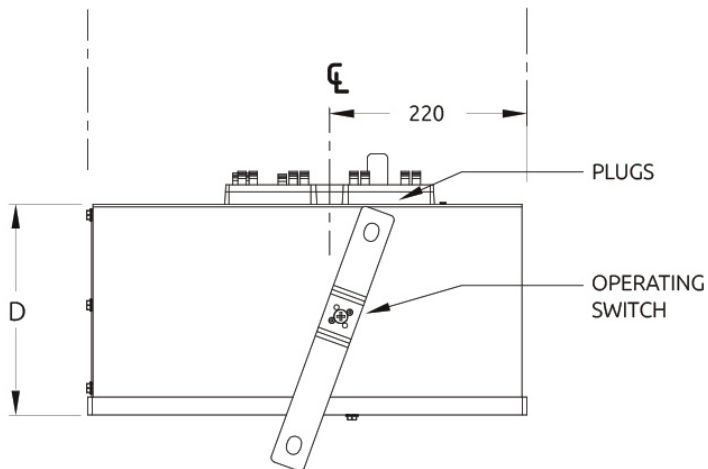

Physical Data

Plug In unit Dimensions

Front View
(500A ~ 800A)

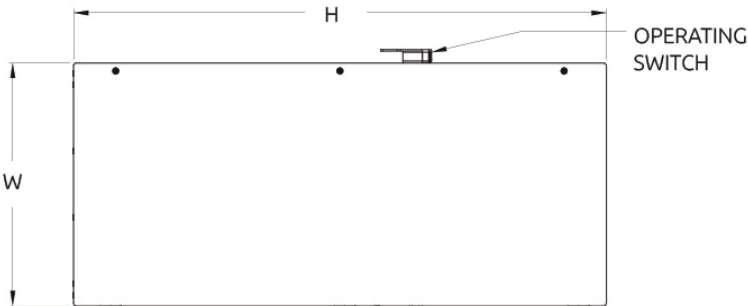

Side View
(500A ~ 800A)

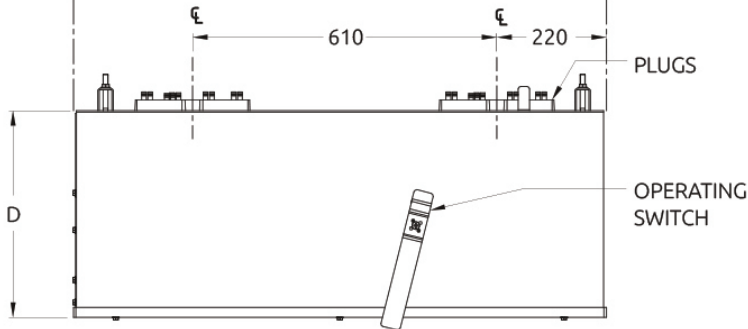

Front View
(800A Above)

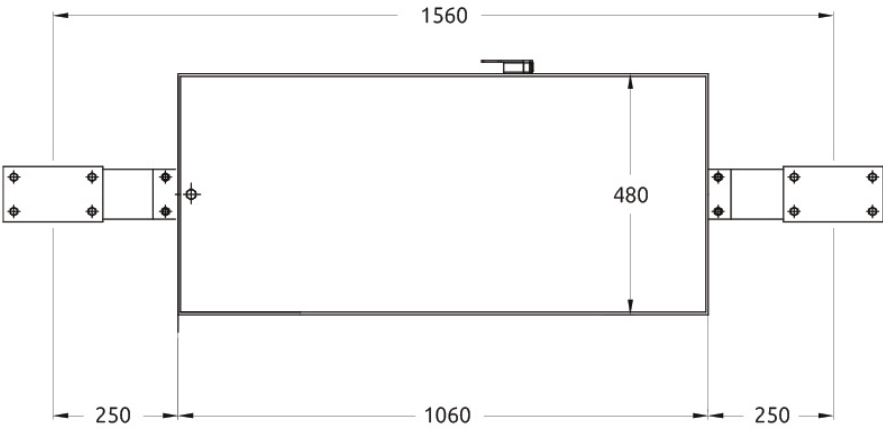

Side View
(800A Above)

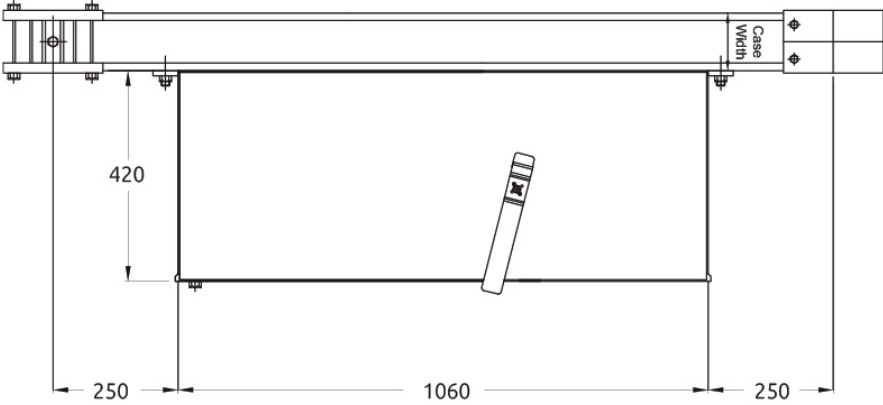

Physical Data

Horizontal Application

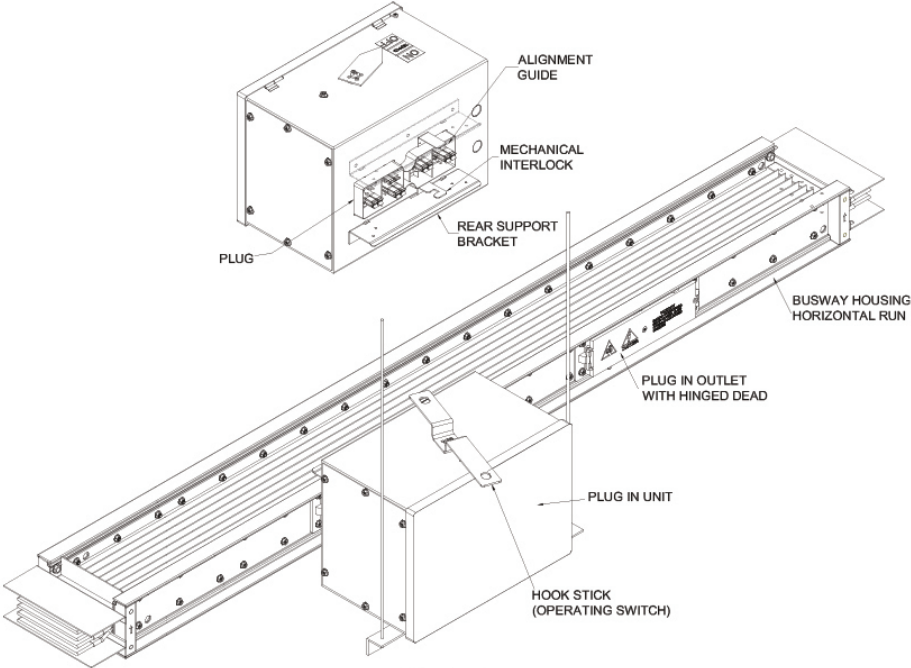

Fig 22.1

Riser Application

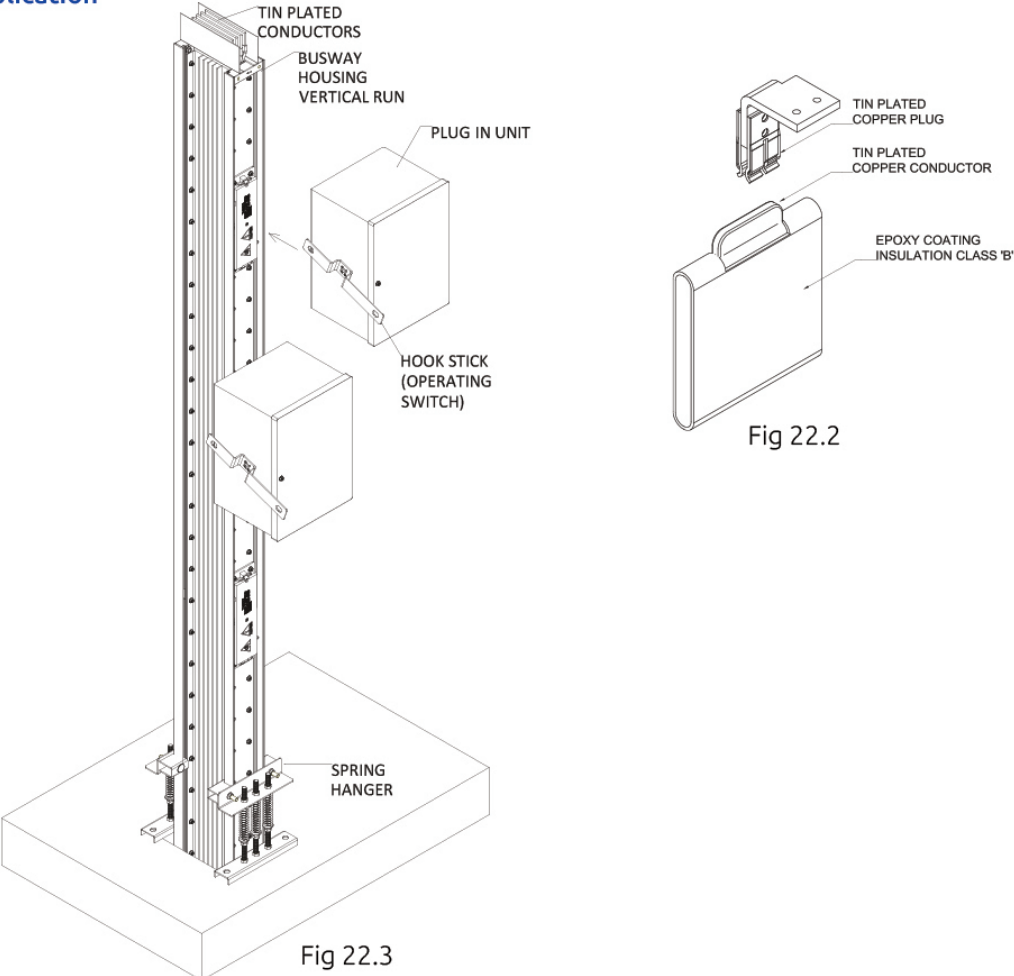

Fig 22.3

Fig 22.2

Physical Data

Joint Stack

Powerduct joint stack features a single bolt with double headed design. The high strength steel bolts together with the Belleville spring washers provide equal pressure across the complete joint contact area to assure proper electrical contact. Double head bolt will shear off to ensure the proper torque is applied.

It is very important to get the joint installed properly and accurately. Improper tightening of the connection bolts will cause the joint overheating after certain period of time during energizing. Powerduct bolt is maintenance free design.

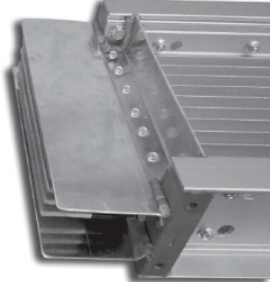
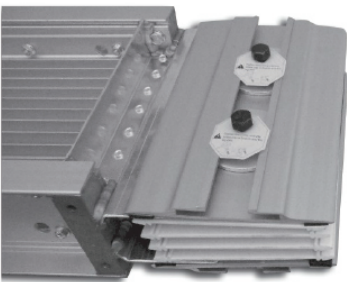

BEFORE

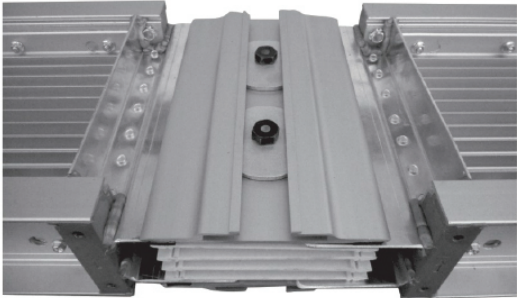

AFTER

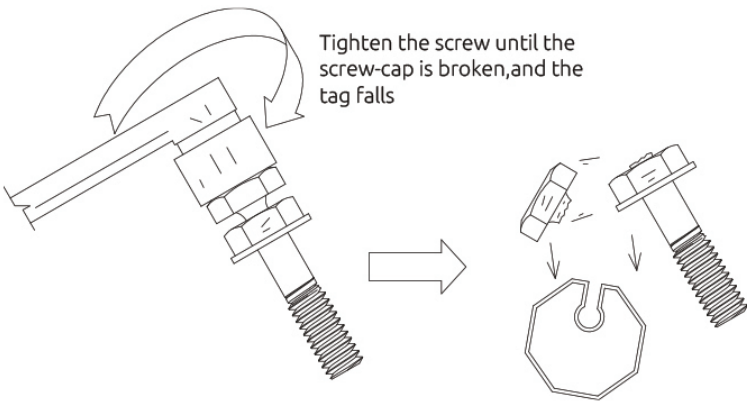

Physical Data

Joint Detail

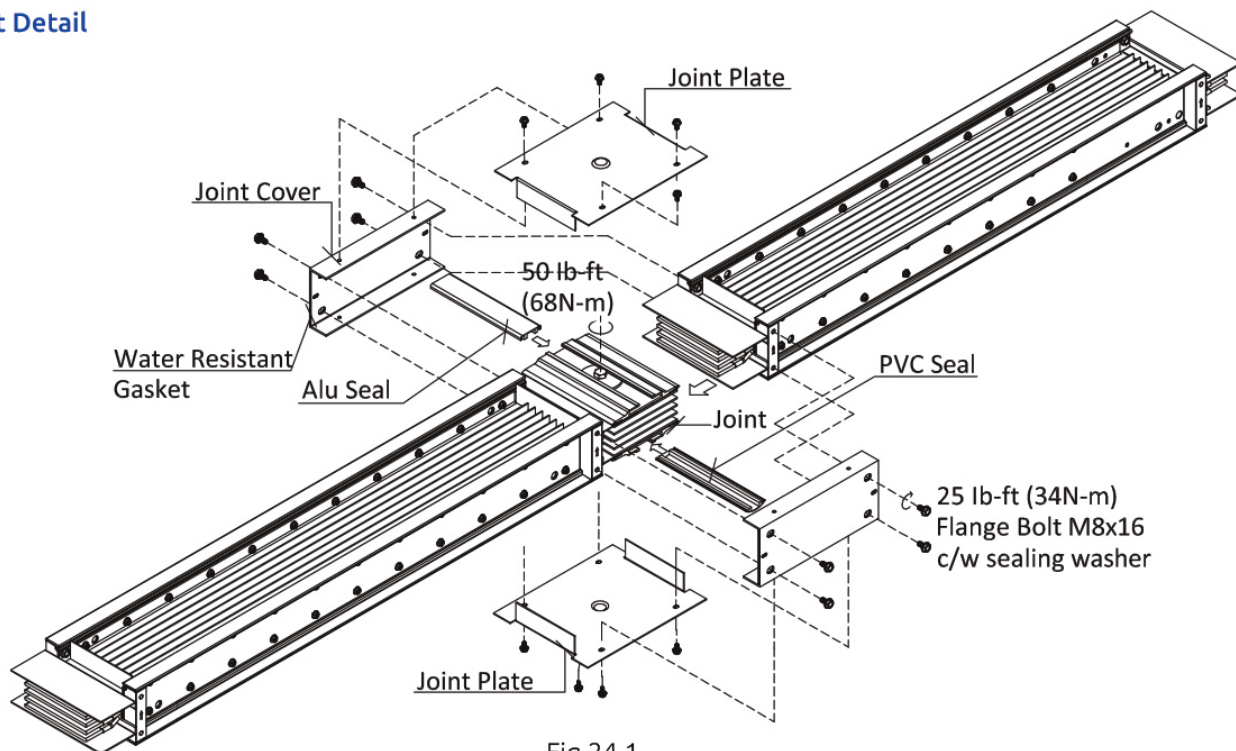
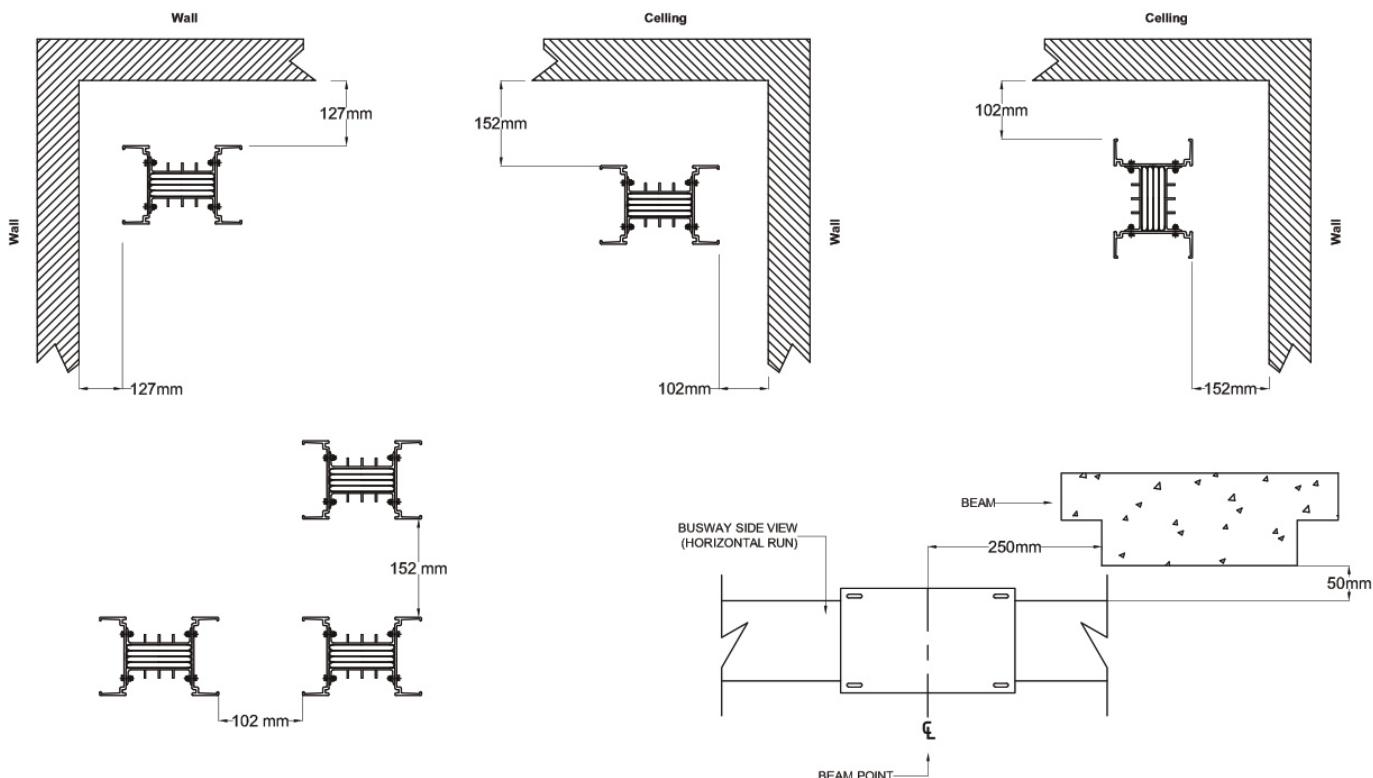

Fig 24.1

Feeder Busway Dimension Spacing Between Runs & Minimum Clearance

The minimum clearances for installing between feeder busway with wall, and ceiling are shown as the following picture below.

Additional clearance may required for the plug-in devices installation. Refer to the next page.



Physical Data

Minimum Distance between parallel-installed busway

Feeder Busway

In case the busway been installed side by side.

(Flatwise Installation)

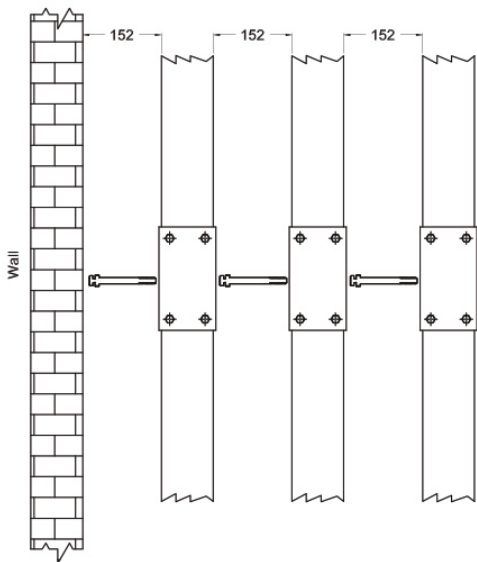

In case the busway been installed side by side.

(Edgewise Installation)

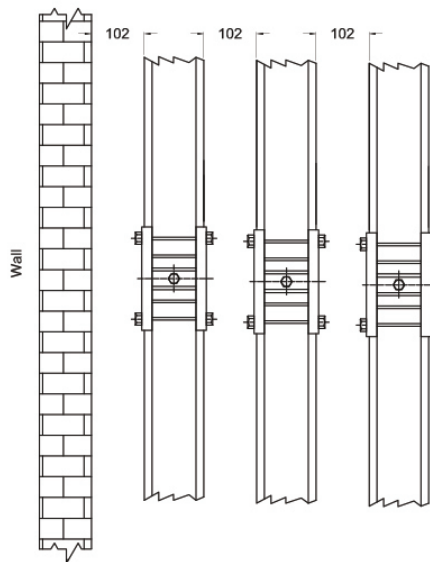

Plug-in type

Minimum clearance of plug-in busway installed in parallel is shown as below. The minimum clearance shall be determined between the plug-in to ensure that 50mm clearance is given. When the busway is to be installed in a tight places, make sure clearance shall be given enough for the plug-in to get opened which is shown as picture below:

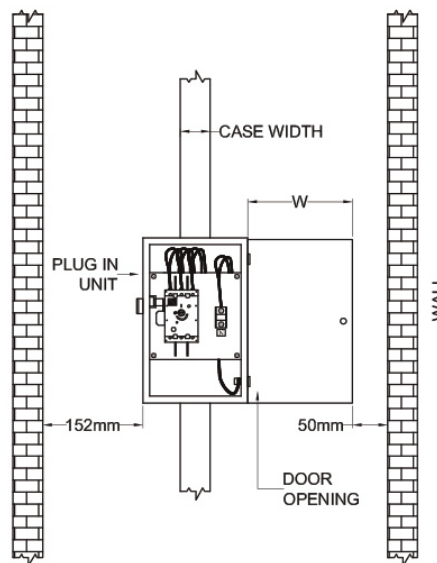
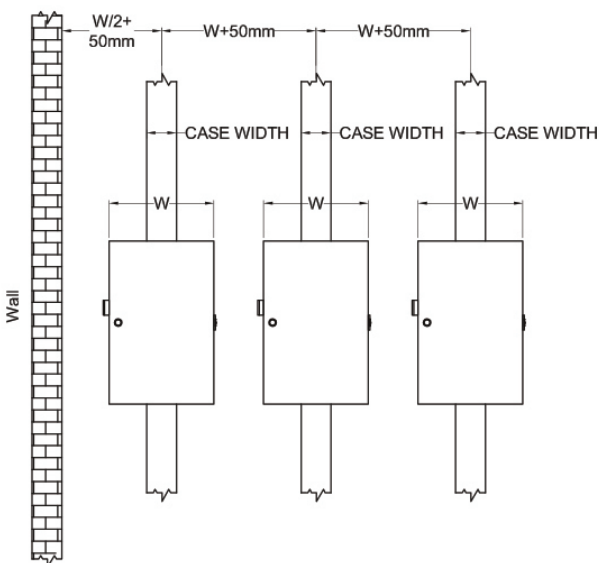

Note

* Dimensions 'W' refer to Table 19.1.

Physical Data

Busway Connection Procedure:

1. Align the sections to be joined by matching up the TOP labels attached to the ends of each section. Use tools provided by manufacturer to ease the installation. Ref. Fig.26.1 and 26.2
2. Slide the sections together.
3. If the joint caps are not already in place, reattach them and hand tighten the mounting screws.
4. Inspect the busway run for straightness in all planes and make any adjustments necessary for good alignment.
5. Tighten the joint bolt to 50 ft-lbs (68N-m) with a 3/4 inch or 19mm socket wrench. When the Belleville washers on both sides are flattened, the bolt is fully tightened. If the double head bolt is used, tighten until the bolt head shear off. (No torque wrench is required) as shown in Fig.26.3
6. Tighten all joint cover flange bolt (M18x16) to 25lb-ft (34N-m) with a 13-mm socket wrench.
7. During the installation, occasionally mega test the assembly to check for any improperly made joints. Resistance should not drop below 1 megaohm per 100 feet of busway. (According to NEMA BU 1)
8. Mega test the complete run before energizing.

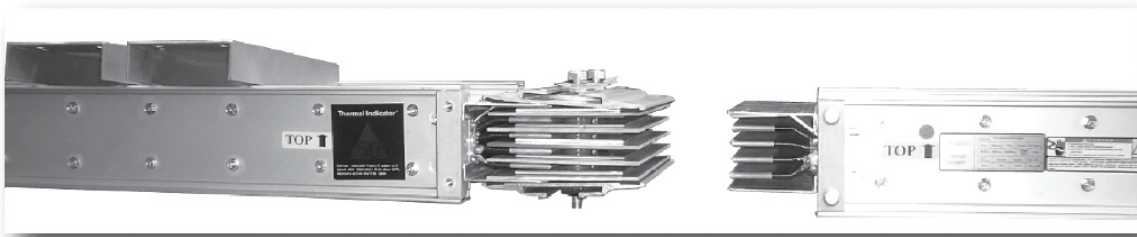

Fig. 26.1

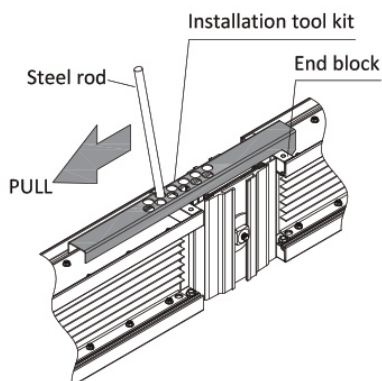

Fig. 26.2



Fig. 26.3

Physical Data

Hangers

Application for horizontal Mounting, cleats shall be mounted for installation at 2 meter intervals. The installer just install all these cleats in the angle irons or U channels to mount the busway at horizontal edgewise or flatwise. In addition, 1/2 inch (12mm) drop rods are recommended with a maximum 10 foot (3840mm) spacing. Drop rods and other hardware must be furnished by the installer.

Please check with manufacturer if cleat quantity provided is insufficient.

Important :

- Maintain good alignment of the drop rods along the busway run.
- Do not support busway at the joint.
- After the busway is secured with the hangers, adjust the hangers on the rods for the correct elevation.
- Busway braces (furnished by the installer) may be required to keep the run straight or to prevent rotation.
- Manufacturer strongly recommends each 2 meter busway adjacent must have busway cleat supported.

Table 27.1 dimension for Figure 27.1 & 27.2

Bars Per Phase	Copper		Dim (mm) Hanger (A)
	Ampere Rating	Busway (W)	
1	400	89	260
	600	99	
	800	114	
	1000	129	
	1200	144	
	1350	159	
	1600	179	
	2000	219	
2	2500	254	356
	3200	295	470
	4000	375	572
3	5000	475	775
	6300	681	775

Bars Per Phase	Aluminium		Dim (mm) Hanger (A)
	Ampere Rating	Busway (W)	
1	400	109	260
	600	109	
	800	124	
	1000	139	
	1200	169	
	1350	194	
	1600	214	
	2000	269	
2	2500	325	470
	3200	405	572
	4000	475	775
3	5000	681	775

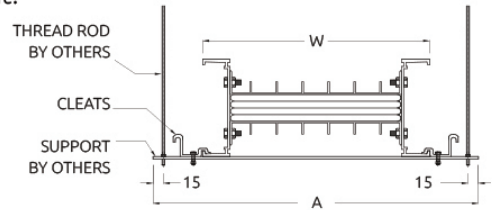

Fig. 27.1 Flatwise mounting

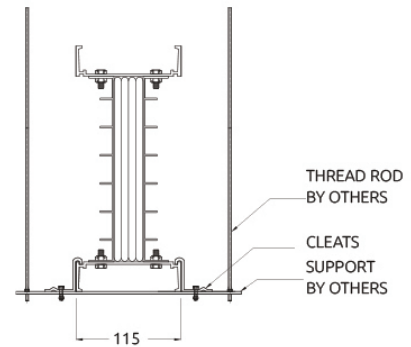
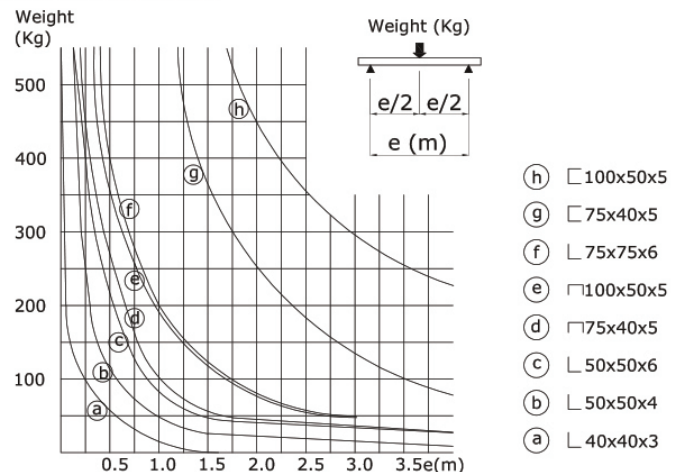

Fig. 27.2 Edgewise mounting

Material use for busway support channel.

- Suggest to use 12mm or 1/2 inch of steel rod.
- It is recommended to use 40x40x3(mm) support channel for 2000A or below busway model while 50x50x6(mm) for 2500A or above busway.
- Please refer to below data during busway installation

Refer to the Table 9.1



Physical Data

Floor Support

Spring Hanger is purposely design to support busway at each floor regardless the busway total length. Intermediate support suggests to be use whenever the floor to floor lever is over 4.8M height. The number of spring provided is based on busway weight.

W = Busway width

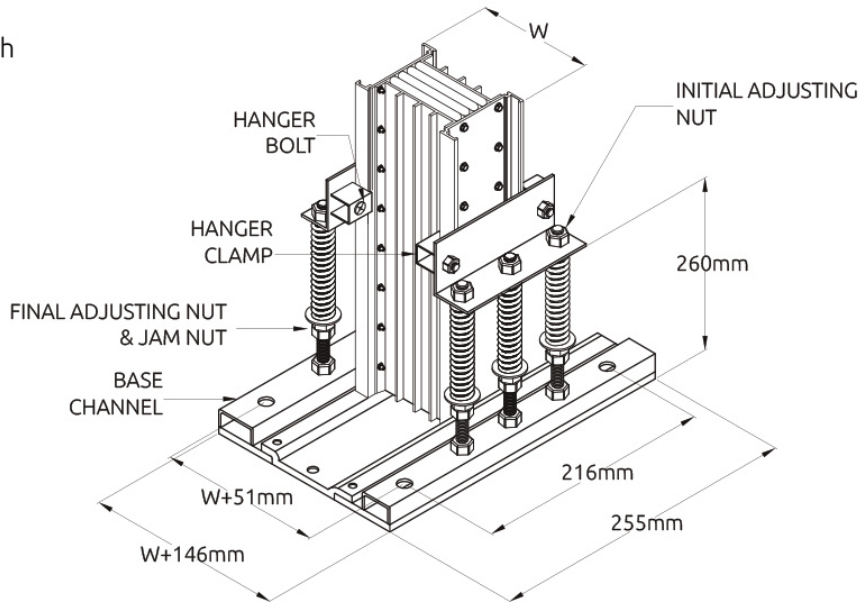

Fig. 28.1

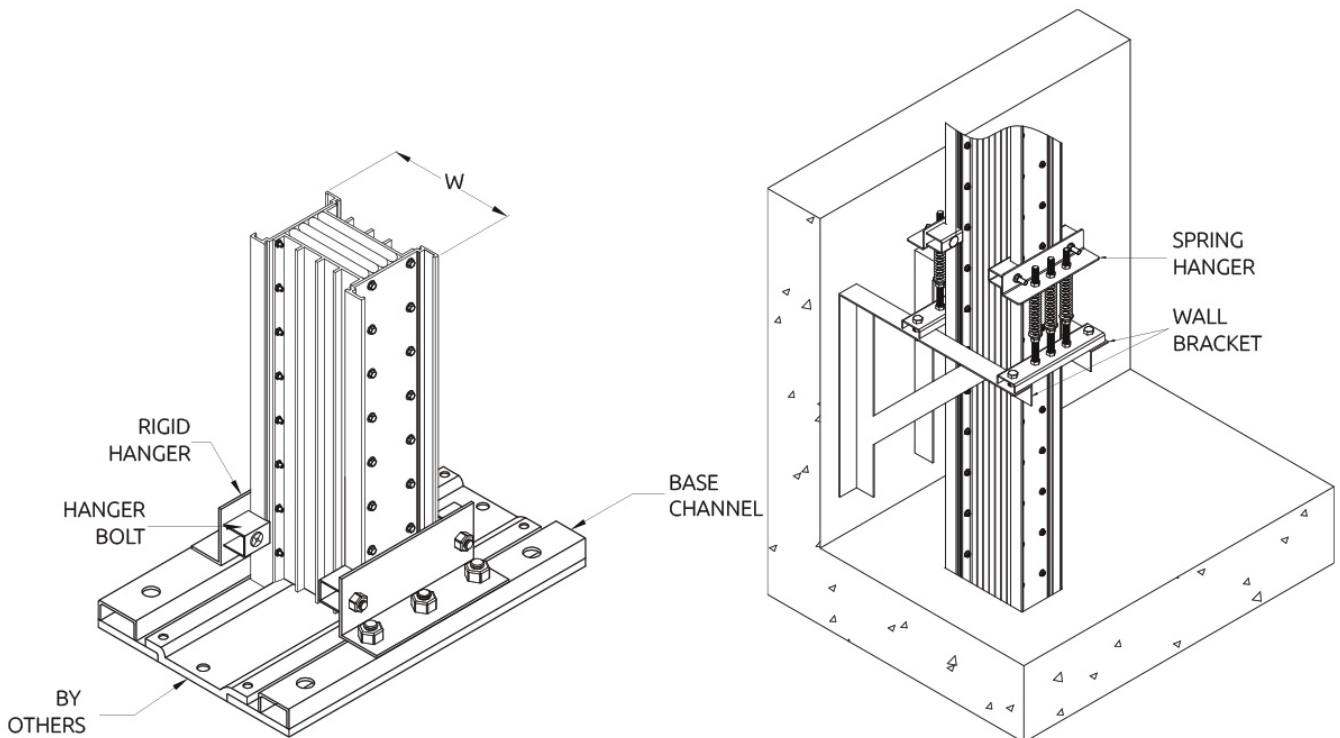
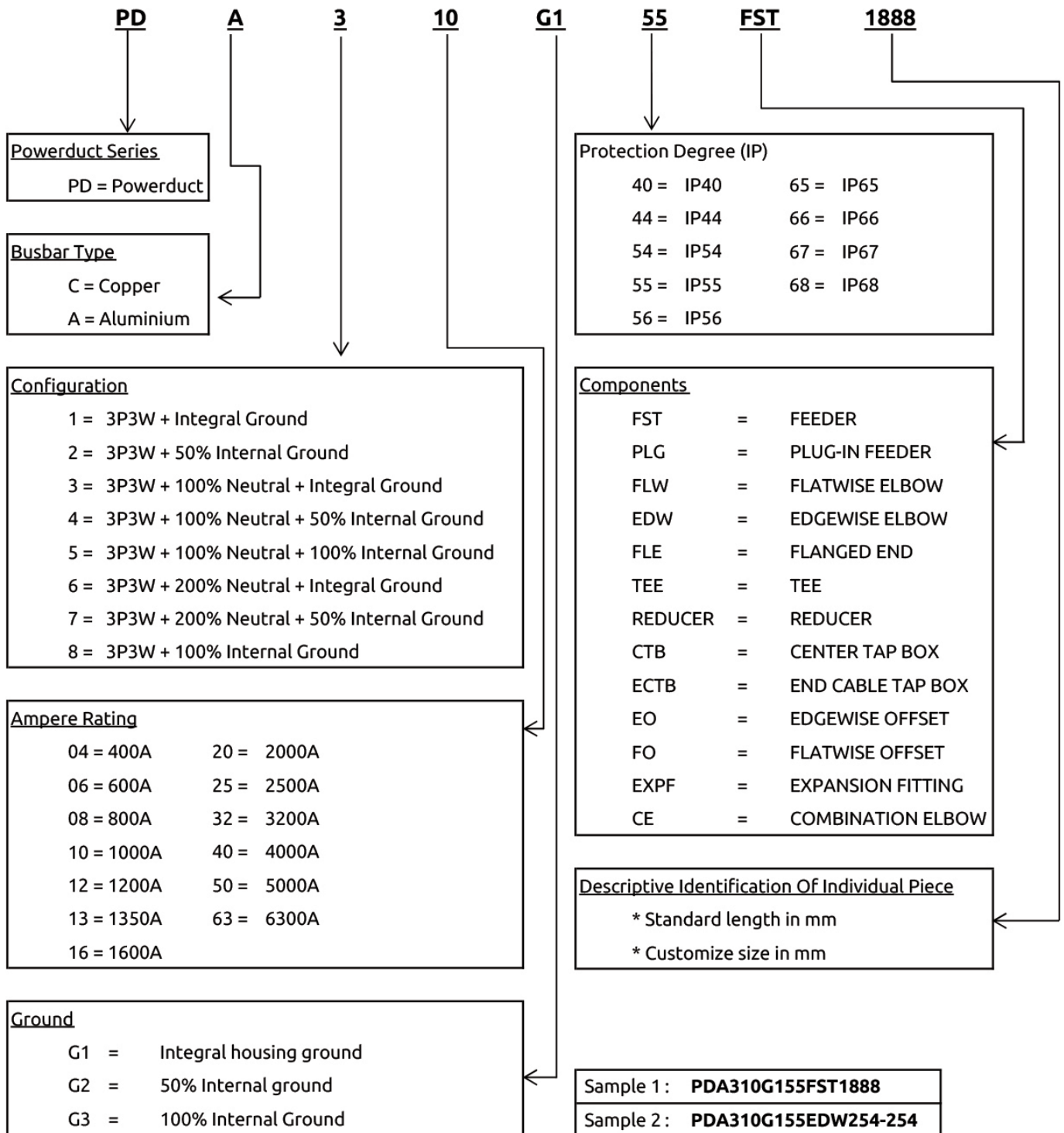

Fig. 28.2

Fig. 28.3

Busway and Fitting



Plug-in unit

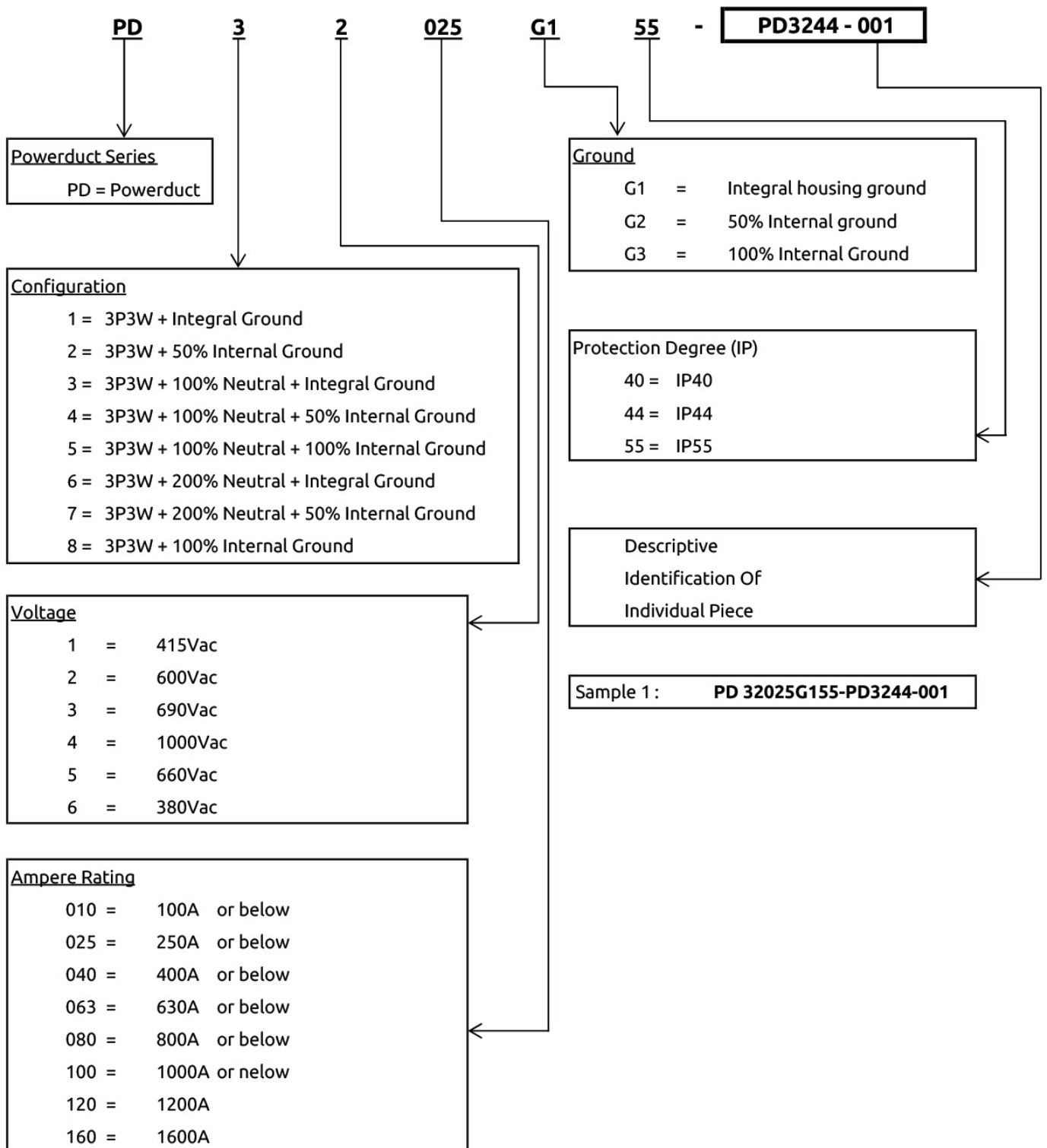

Busway System

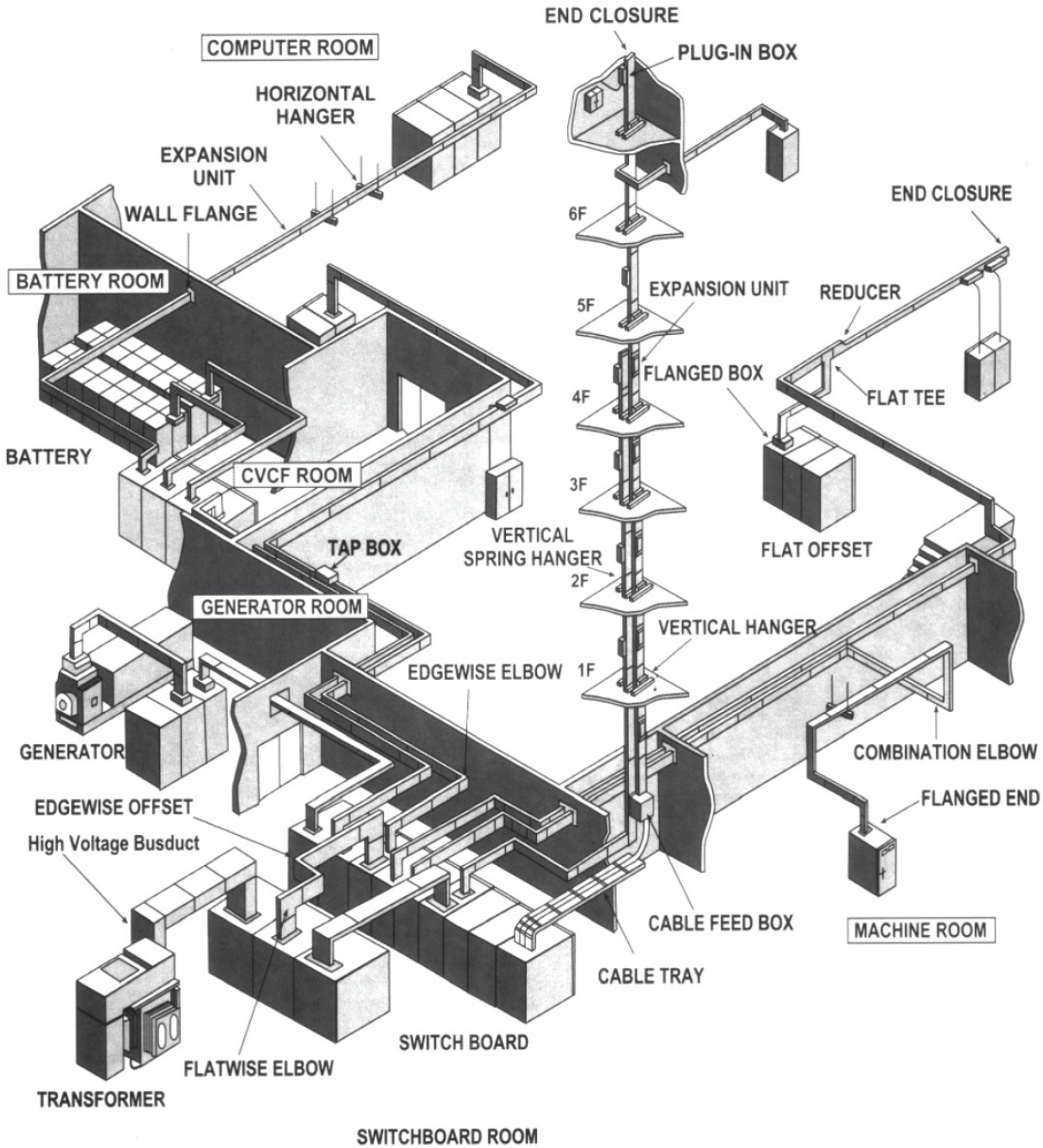

Job Reference

More than 2000 jobs has been installed in worldwide market such as in:

- OIL & GAS INDUSTRIES
- MEDICAL CENTER
- RAILWAY LINE STATION
- AIRPORT
- FINANCIAL CENTER
- COOLING TOWERS
- HEAVY INDUSTRIES
- HIGH TECH INDUSTRIES
- SMALL AND MEDIUM INDUSTRIES
- EDUCATION BUILDING
- POWER STATION
- SHIPYARD
- SHIP
- HIGH RISE RESIDENTIAL TOWER
- TUNNELS
- TELECOMMUNICATION TOWER
- COMMERCIAL BUILDING AND COMPLEX
- DATA CENTER
- HOTEL



Job Reference

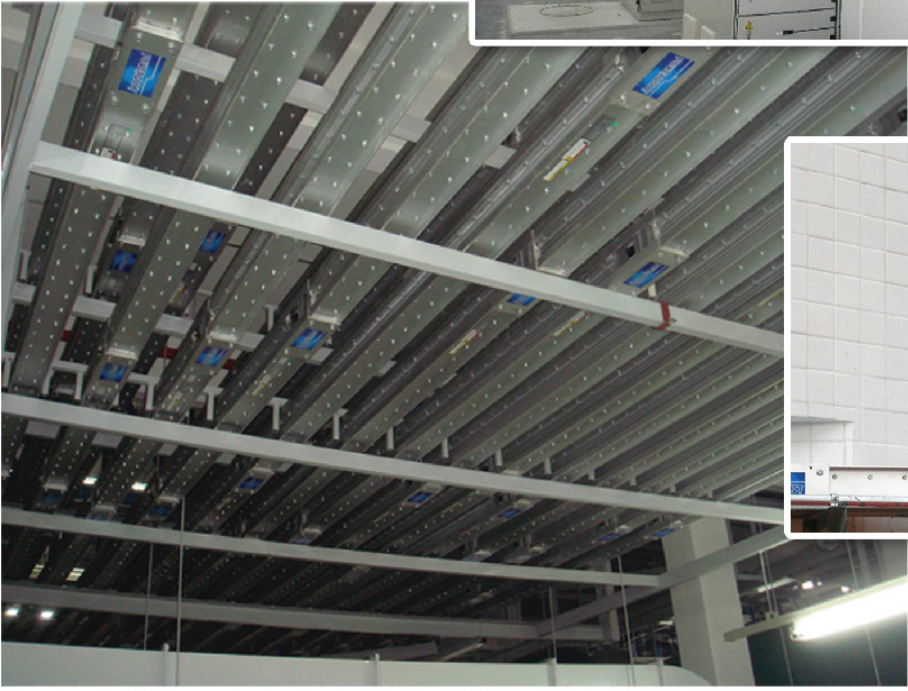
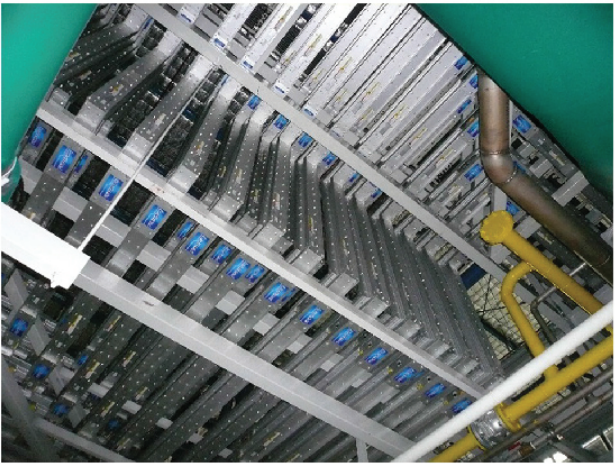

Fire Rated Powerduct busway system is also available, Fire Rated Powerduct is specially designed upon customer's request where the applications in hazardous environment system. The rating available from 400A to 6300A. The design and construction is completely tested accordance to IEC 60331-1:2009, BS 6387:2013(C,W,Z) / IEC 61034:2005 (measurement of smoke density).

IEC 60331-1:2009

The busbars provide circuit integrity for 120 minutes at 830°C.

BS 6387:2013 / IEC 61034:2005

The busbars provide circuit integrity for :

- Protocol C - Resistance to fire alone
- Protocol W - Resistance to fire with water
- Protocol Z - Resistance to fire with mechanical check.

The busbars provide measurement of smoke density.

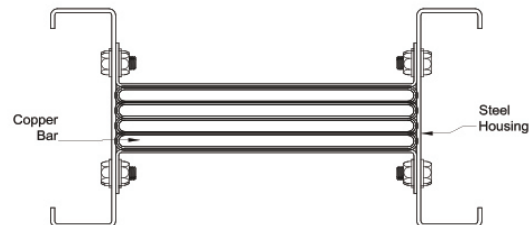
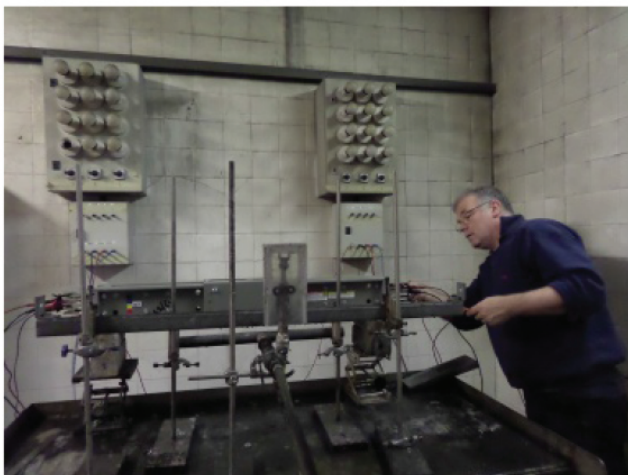



POWER PLUG BUSDUCT SDN BHD
[200101010162 (545918-D)]

ADD: No.17, Jalan SiLC 1/4,
Kawasan Perindustrian SiLC,
79200 Iskandar Puteri, Johor, Malaysia.
Johor Darul Ta'zim, Malaysia.

TEL: +607-532 1988 / +607-532 1922

FAX: +607-532 1177

WEB: www.ppbc.com.my

Publish in year 2019

** Technical details and dimesions for the products are subject to continuing revision and engineering update without notice.



CE ASTA CCA

